

INDEX

MACHINE DESCRIPTION.....	2
ACCESSORIES.....	3
IDENTIFICATION TAG.....	3
GENERAL NOTES BY THE DELIVERY	3
SAFETY PRESCRIPTIONS.....	4
HACCP REGULATIONS	7
TECHNICAL SPECIFICATIONS	8
DIMENSIONS.....	8
INSTALLATION	10
CONTROL PANNELS	12
STARTING AND WORKING	12
LOCKING/UNLOCKING THE KEYBOARD.....	12
WORKING SETPOINT AND CONFIGURATION PARAMETERS	13
LOADING THE PRODUCT.....	23
STOPPING	23
DEFROSTING	23
ALARMS AND SIGNALS.....	24
WORKING IRREGULARITIES	29
GENERAL CLEANING AND MAINTENANCE	29
MAINTENANCE CABINETS STAINLESS STEEL	30
MAINTENANCE CABINETS VX-PET.....	31
USAGE INTERRUPTIONS	32
MALFUNCTIONING	33
WASTE DISPOSAL AND DEMOLITION.....	33
INVERTING THE DOOR (exception made for glass door versions).....	34
INVERTING THE 1/2 DOOR.....	35
REFRIGERANT MATERIAL SAFETY DATA SHEET	36
WIRING DIAGRAM PLATE.....	37

MACHINE DESCRIPTION

This appliance has been designed for chilling and preserving foods. Any other use is to be considered improper.

ATTENTION: the appliances are not suitable for installation outdoors or in environments subject to the action of the elements.

The manufacturer cannot be held liable for improper use of its appliance.

These refrigerating cabinets come with "CHILLING/POSITIVE TEMPERATURE" and "FREEZING/NEGATIVE TEMPERATURE" refrigerating systems in order to satisfy food preservation at different temperatures.

Appliances are equipped with a finned evaporator which prevents oxidation, an hermetic compressor, a copper-aluminium condenser and a digital thermoregulator.

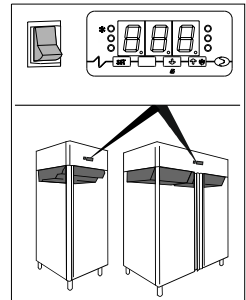

The compressors are installed in the upper part of the cabinets for a better airing and heat dissipation.

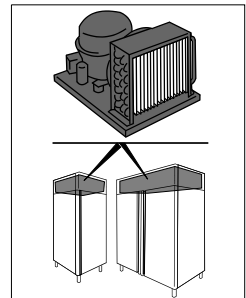

The condense collecting tray is placed behind the refrigerator and is equipped with an automatic system for evacuation of the condense water.

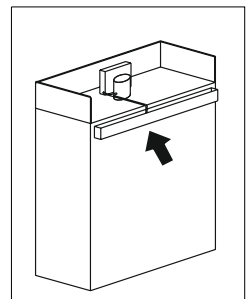

The lighting system, if provided, is located on the lower side of the instrument panel. The doors are provided with key to ensure a safe closing (except for mod. ...LTE).

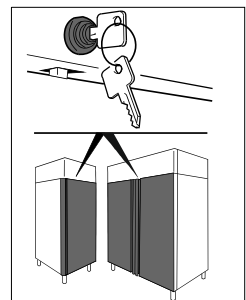

The areas that come into contact with the product are in steel or covered in non-toxic plastic material.

An refrigerant fluid, approved by current legislation, is used in the refrigerating units.

In case of storage, ensure proper ventilation, temperature between -20°C +50°C, relative humidity between 30% and 80% and an atmosphere that is dry and not dusty.

ACCESSORIES

The appliance can be equipped with the following accessories on request (see "general catalogue").

IDENTIFICATION TAG

For any communication with the manufacturer, always mention the MODEL and the SERIAL NUMBER of the appliance which are reported on the technical feature plate.

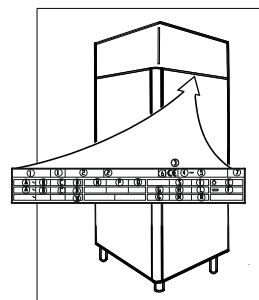

Refrigerator rating plate containing the following ratings

①				②				③		④			⑤			⑥		⑦	
A ~ B C D				Z3				Z1		Z			R		E		F		
A ~ B C D				Z2				G H L			G H M		Z4		Z		Z		
~				Y Z				G H M			G H M		Z4		Z		Z		

- | | |
|---|--|
| <ul style="list-style-type: none"> 1) MODEL 2) MANUFACTURER'S NAME AND ADDRESS 3) CE MARK 4) YEAR OF MAKE 5) SERIAL NUMBER 6) ELECTRIC INSULATING GRADE 7) ELECTRIC PROTECTION GRADE A) POWER SUPPLY VOLTAGE B) ELECTRIC CURRENT RATE C) POWER SUPPLY FREQUENCY D) RATED POWER | <ul style="list-style-type: none"> E) TOTAL LAMP POWER F) FUSIBLE CURRENT G) REFRIGERATING FLUID TYPE H) REFRIGERATING FLUID QUANTITY L) AMBIENT TEMPERATURE R) WEEE SYMBOL W) HEATING SECTION POWER Z1) RATED STORAGE VOLUME (RSV) Z2) FLUID FOAMING Z3) TEMPERATURE RANGE Z4) GWP |
|---|--|

GENERAL NOTES BY THE DELIVERY

At the delivery inspect that the packing is not injured and that it has not been damaged during the transport.

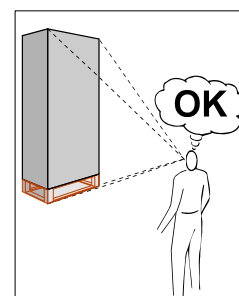

After having unpacked the refrigerator verify that all the parts are present and that the characteristics and the condition correspond to the order specifications. Otherwise contact immediately the retailer.

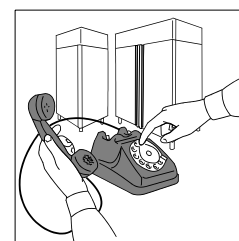

We congratulate you on your choice and we hope that you can use our refrigerating cabinets to their utmost, by following the necessary instructions and precautions contained in this manual.

But, remember that any reproduction of this manual is forbidden and that due to a constant pursuit of innovation and technological quality, the features hereby presented could change without notice.

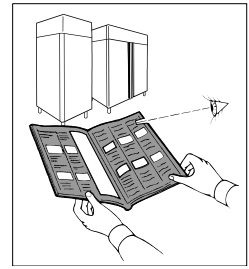

SAFETY PRESCRIPTIONS

WARNING: before any maintenance or cleaning operation the machine must be insulated from the current:

– switch the general cut-out in OFF position.

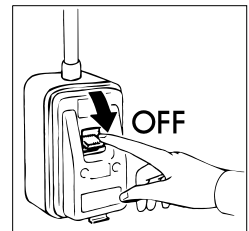

– remove the plug.

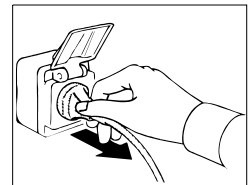

WARNING: do not use current taps or plugs not provided with grounding.

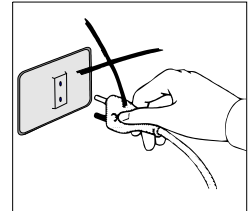

The socket must be provided with GROUNDING.

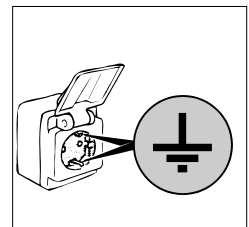

WARNING: do not use adapters or patch cords for the connection to the electric line.

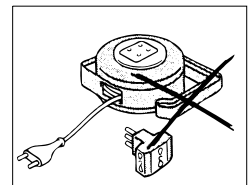

WARNING: if the power cord is damaged it must be replaced by the manufacturer, a service or qualified personnel to avoid risks.

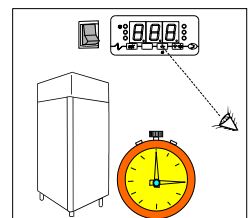

WARNING: wait the time necessary to reach the setted temperature before to introduce the food to preserve.

Always cover the food with the special film before to put it into the refrigerator.

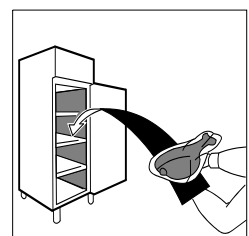

WARNING: do not introduce hot foods or drinks into the refrigerator.

WARNING: do not store explosive substances such as aerosol cans with a flammable propellant in this appliance.

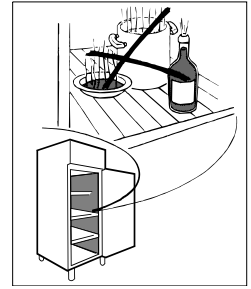

WARNING: Store the food to be preserved so as not to brim over the grids. Thus air flow will not be hampered. Do not obstruct fan intake area.

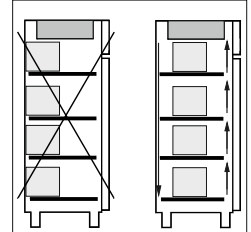

WARNING: do not do the cleaning around the refrigerator when the door is open.



Do not wash the appliance by spraying high-pressure water on the machine.

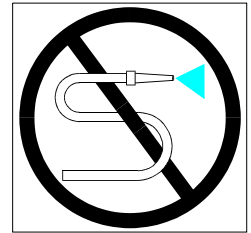

WARNING: do not use substances with base of chlorine (chlorine water, muriatic acid, etc.) or however toxic for the cleaning or near the refrigerators.

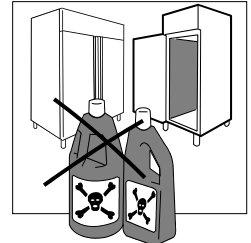

WARNING: do not cover the upper side of the refrigerator or the air inlets when the machine is working or live.

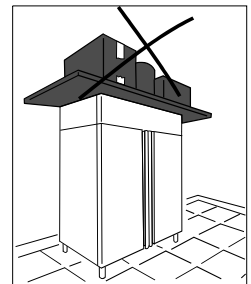

WARNING: do not place objects on the refrigerator bottom. Use the grids provided. For info Max weight distributed on the racks to see product details.

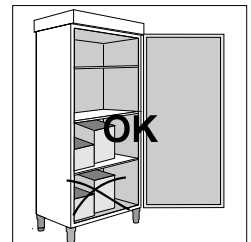

WARNING: It is recommended that the keys be kept out of reach of children.

WARNING: Do not use mechanical devices nor other means to speed up the thawing process other than those recommended by the manufacturer.

WARNING: do not damage the coolant circuit.

WARNING: Do not use electrical appliances inside compartments.

The cleaning and maintenance of the refrigerating engine and the compressor area needs the intervention of a skilled technician, therefore it cannot be done by other persons.

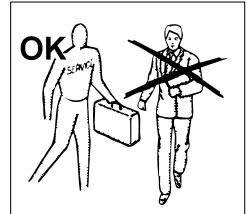

For a maintenance intervention or in case of anomaly disconnect completely the machine; ask for the TECHNICAL SERVICE to an entitled center and the use of original spare parts.

The unfulfilment of this above can endanger the safety state of the refrigerators.

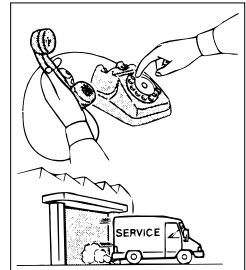

Climate Class	Ambient temperature
3 (SN)	+10°C ---> +32°C
4 (N)	+16°C ---> +32°C
4+ (ST)	+16°C ---> +38°C
4+ (SN-ST)	+10°C ---> +38°C
5 (T)	+16°C ---> +43°C
5 (SN-T)	+10°C ---> +43°C

HACCP REGULATIONS

- WARNING:** Raw vegetables, eggs and poultry **CANNOT** be kept in the same refrigerated place. Poultry must be kept in the proper refrigerated place.
- WARNING:** Avoid preserving food with a temperature between 10°C and 60°C. Make use of the proper appliances (blast chillers) to reduce the temperature to the core of the food.
- WARNING:** When taking the foodstuffs out of the refrigerator, check the expiry date marked on the package, and take out those with the nearest expiry date. If you note an expired food, it has to be kept away from the refrigerator and eliminated, reporting what happened to the person in charge of the firm where you work.
- WARNING:** Easily perishable foodstuffs must be taken out of the refrigerated ambient as late as possible in order to be exposed to room temperature only the necessary time.
- WARNING:** Do not refreeze foodstuffs previously defrosted.
- WARNING:** Number the equipment and check twice a day the temperature taken by recording the figures on a proper sheet to be kept for 24 months.
- WARNING:** Any interruption of current to the refrigerators can be carried out by checking the downtime with an electric clock in order to eliminate the foodstuffs that could perish.

Maximum temperatures admitted for goods

Foodstuff	Normal storage temperature (°C)	Maximum temperature of carriage (°C)
Fresh pasteurized milk	0÷+4	9
Fresh cream	0÷+4	9
Yoghurt, ricotta, fresh cheese	0÷+2	9
Frozen fish	0÷+2	0÷+4
Beef and pork	0÷+3	10
Poultry	0÷+4	8
Rabbit	0÷+2	8
Ground-game	0÷+2	8
Big game	0÷+2	8
Offal	0÷+3	8
Frozen food	-23÷-24	-18
Packed ice-cream	-18÷-20	-18
Fruit and vegetables	0÷+4	room temperature

TECHNICAL SPECIFICATIONS

Last page on the handbook: technical specifications.

DIMENSIONS

Please refer to the dimensions of your own appliance.

- *Mod. with internal evaporator*

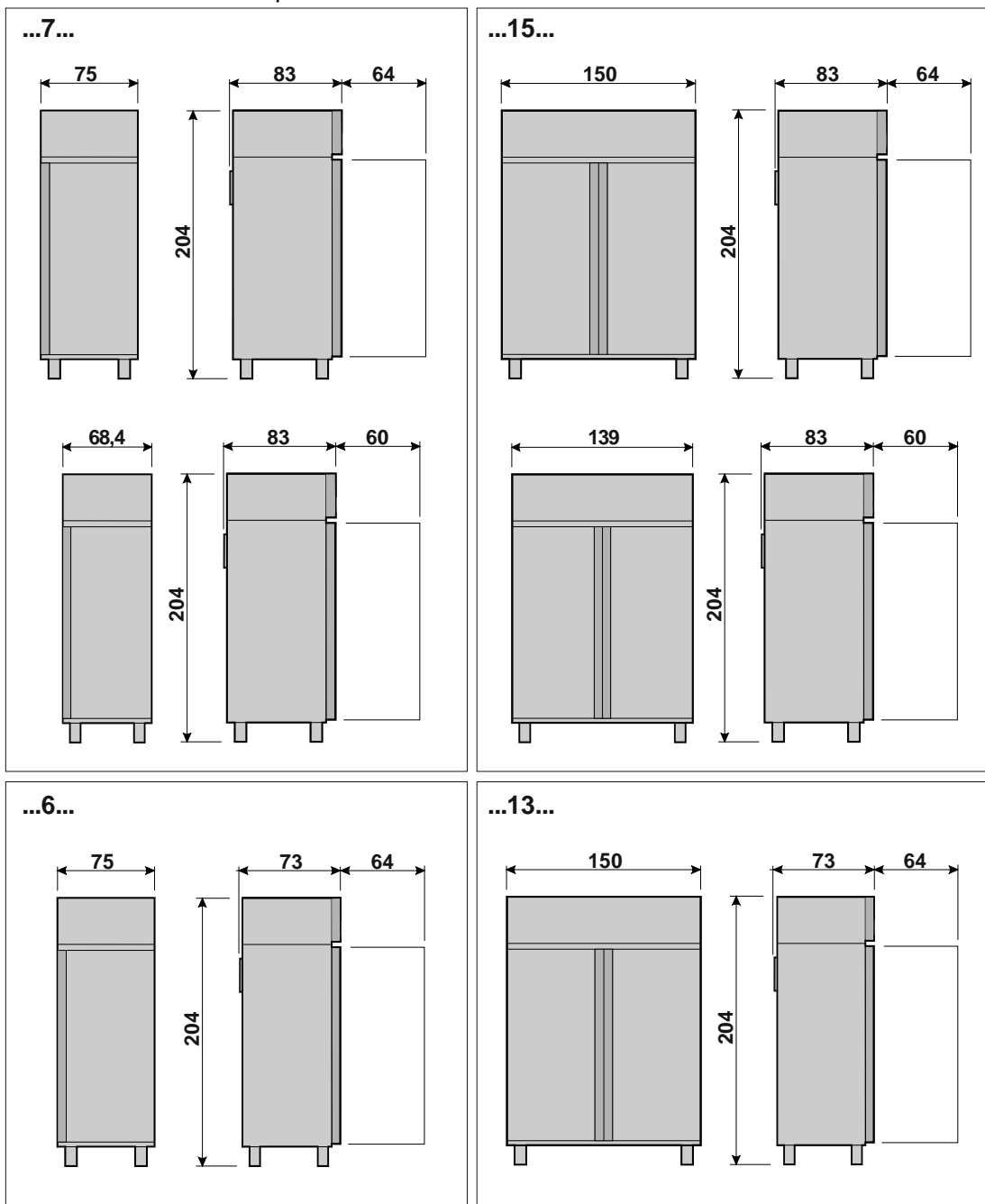

• Mod. with external evaporator

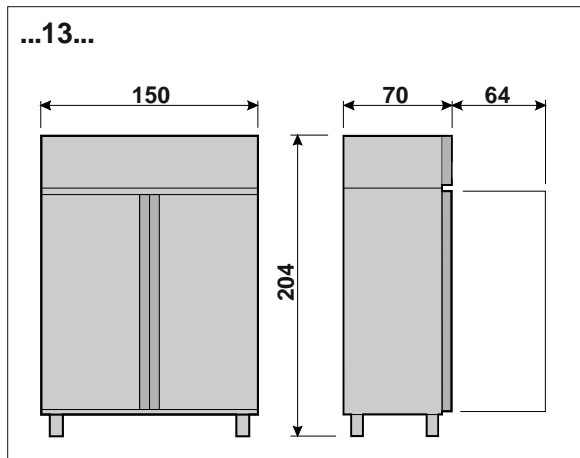
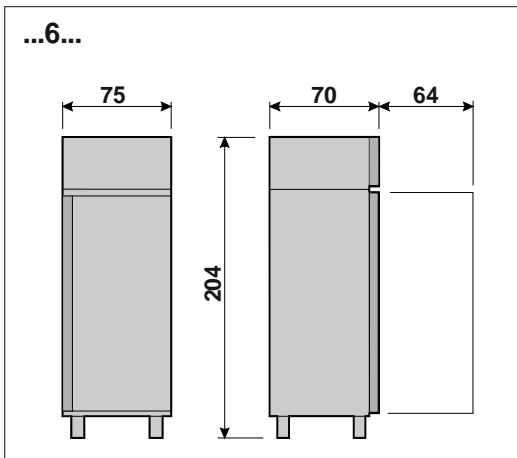
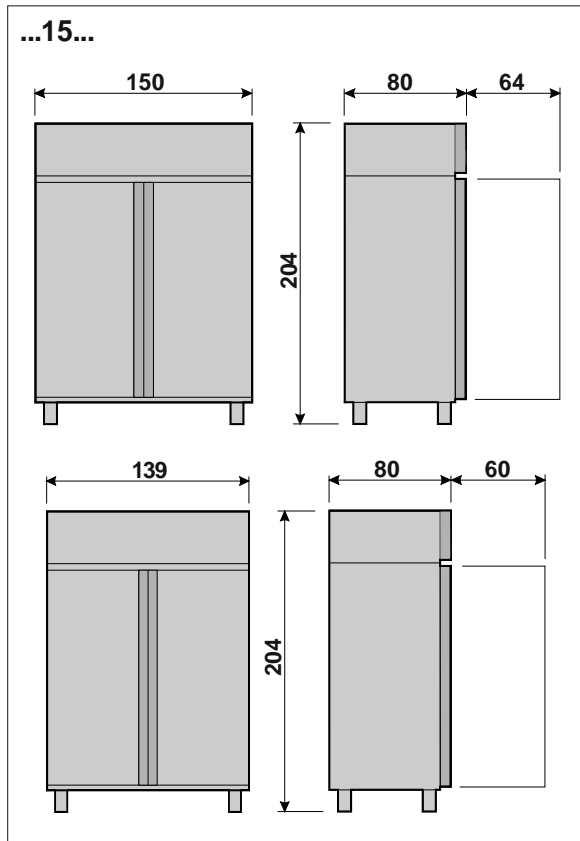
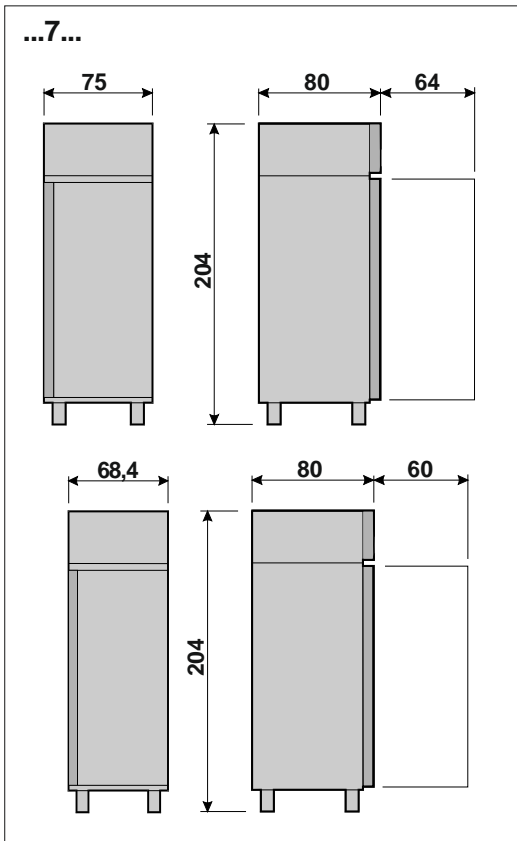

• Mod. Ice-cream

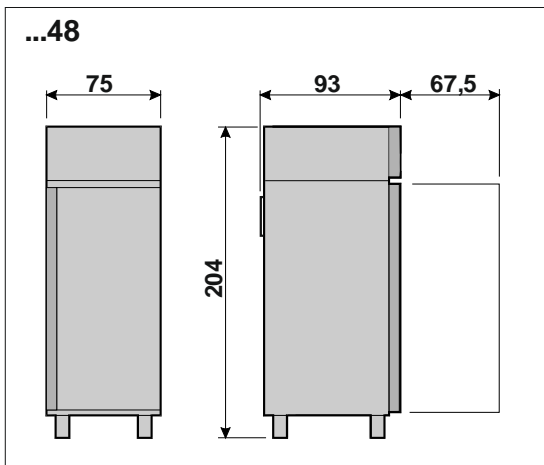

• Mod. two rooms

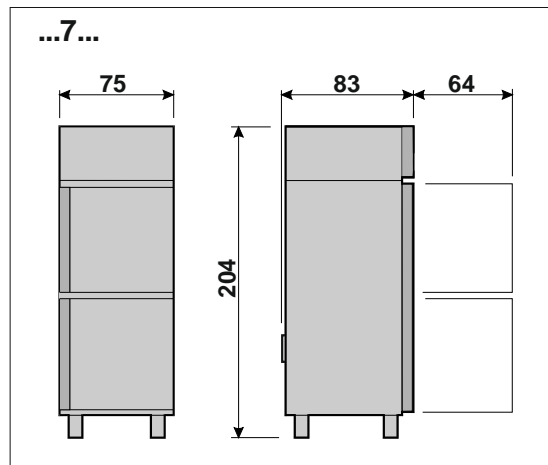

INSTALLATION

The refrigerators are always send packed and on pallet.

On receiving and after having unpacked in case of dammagages or missing pieces act as described in the chapter "GENERAL NOTES BY THE DELIVERY".

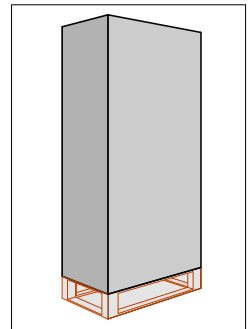

All setting up and starting operations are to be carried out by skilled staff.

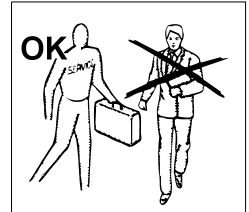

Remove the packing box with care so as not to dent the equipment surface.

WARNING: package parts (plastic bags, polystyrene foam, nails and the like) are dangerous for children and must not be left within their reach.

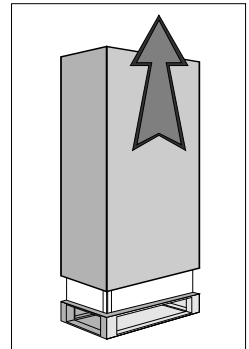

With a fork truck lift pull up the refrigerator and take it to his place paying attention not to unbalance the load.

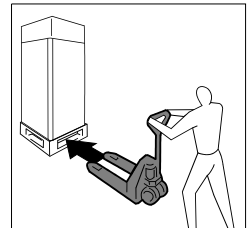

WARNING: never place the refrigerator horizontally during transport; this may cause serious structure and system damage.

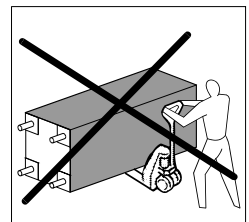

WARNING: whether for the positioning or for further riplacements do not push or pull the refrigerator, to avoid to upset it or to damage some parts.

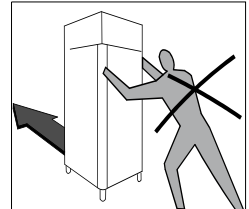

WARNING: do not place the cabinet in the vicinity of heat/ignition sources or in environments with high temperatures and/or highly flammable materials.

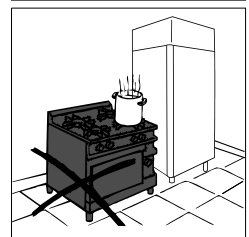

WARNING: distance from the ceiling should be 50 cm at least. Appliances can be placed next to each other, but in case of condensation space them out 20 cm at least.

Remove protective film from product.

This may cause unpleasant static electricity discharge which, however, is not dangerous.

The inconvenience is reduced or prevented by continuously holding the refrigerator with one hand or grounding the package.

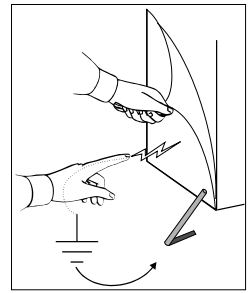

After having positioned the machine remove the pallet using a chisel and a hammer, paying attention not to damage the feet under the blocks or the refrigerator.

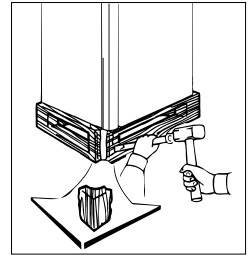

Draw the stiffening block from the port under the machine.

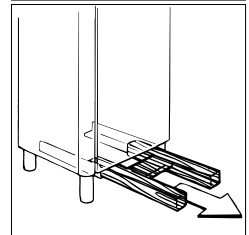

Now it is possible to regulate the feet.

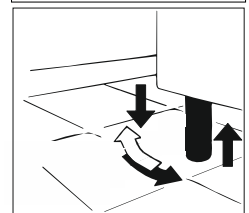

Put the appliance at level by keeping it slightly inclined at its back in order to allow the optimum self-closing door.

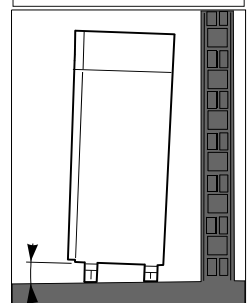

Clean with tepid water and neutral soap (as written in the chapter "CLEANING") and mount the fittings placed into the refrigerator.

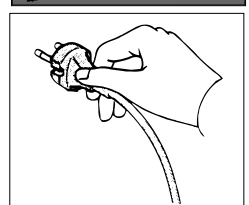

The refrigerator is supplied with an electric plug, SCHUKO type. Make sure it complies with EN60320 and national regulations. Otherwise, replace with a complying one.

WARNING: In order to reduce risks related to flammability, this operation must be performed by a qualified technician.



Signal warning of flammability due to the presence of flammable refrigerant (R290 or R600a).

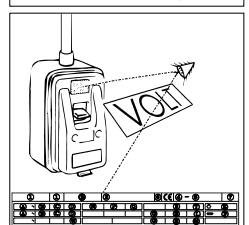

Check that the line voltage corresponds to the one referred on the refrigerator's identification tag.

Then insert the plug into the current tap.

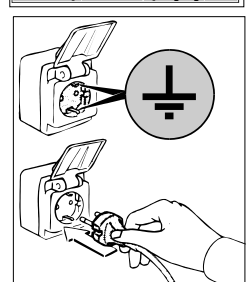

Now the installation has come to end.

CONTROL PANELS

All the refrigerators are equipped with a general switch and a thermoregulator:

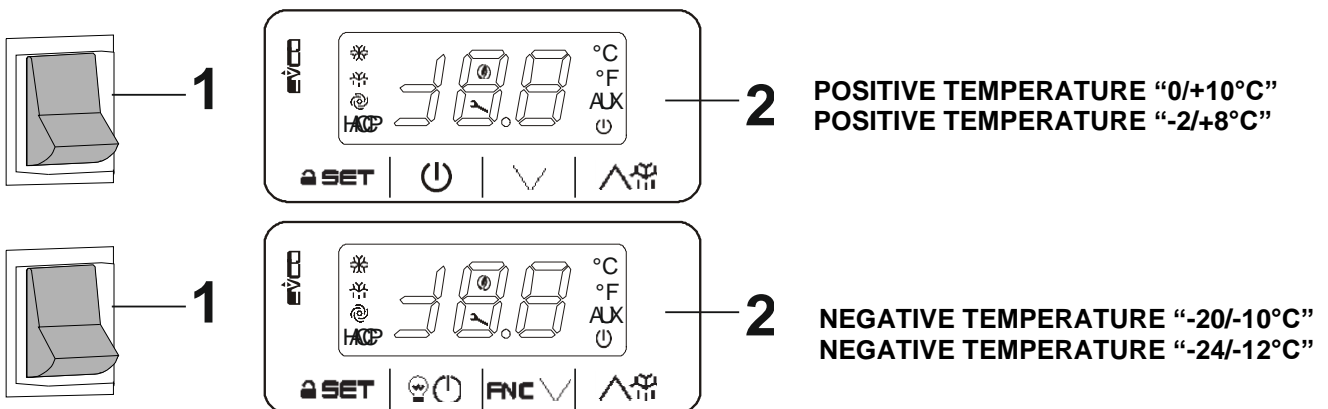

The controls for the models monocolumn with two rooms, are set on the control board so that the control on the right corresponds to the upper room, while the left one corresponds to the bottom room.

STARTING AND WORKING

To start operation, follow this procedure:

- Insert the plug into the current tap;
- position the line switch on ON;
- push the main switch (1); the green indicator turns on;

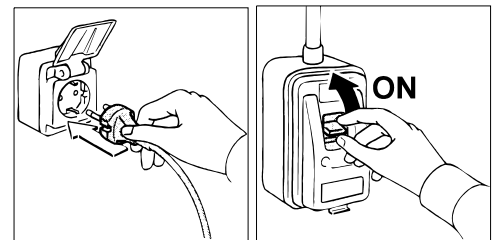

Now set the operating temperature with the thermoregulator (2).

Check on the thermoregulator display (2) that the internal temperature of the counter corresponds to the set value.

THERMOREGULATOR OPERATION

The thermoregulator will cycle the compressor and off determined by the Set-Point and Differential temperature.

The Set-Point is the adjustable preprogrammed temperature which off the compressor.

The Differential is the temperature that is added to the Set-Point temperature that will restart the compressor.

Example

(Set-Point) -2°C +5°C (Differential)

The compressor will cycle off -2°C and back on at +3°C

The display of the thermoregulator shows the internal **air** temperature of the cabinet, not of the product.

LOCKING/UNLOCKING THE KEYBOARD

To lock the keyboard proceed as follows:

- Make sure no procedure is in progress
- Do not operate for 30 s: the display will show the message "**Loc**" for 1 s and the keyboard shall lock automatically.

If the keyboard is locked, you will not be allowed to:

- show the evaporator temperature
- activate the defrost by hand
- modify the working setpoint

These operations provoke the visualization of the label “Loc” 1 s.

To unlock the keyboard:

- Touch a key for 1 s: the display will show the message “UnL” for 1 s.

WORKING SETPOINT AND CONFIGURATION PARAMETERS

POSITIVE TEMPERATURE “0/+10°C”

Setting the working setpoint

- Make sure that the keyboard is not locked and that no procedure is in progress
- Touch the **SET** key: the LED ❄️ will flash
- Touch the \wedge or \vee key within 15 s; see also r1 and r2 parameters
- Touch the **SET** key or do not operate for 15 s: the LED ❄️ will switch off after which, the device will exit the procedure.

To exit the procedure before the operation is complete:

- Touch the ⏸️ (any changes will not be saved)

The working setpoint can also be set via **SP** parameter.

Working setpoints

LABEL	MIN.	MAS.	U.M.	WORKING SETPOINT
r1	r2		°C/°F (1)	working setpoint; see also r0 and r12

Setting the configuration parameters

To access the procedure:

- Make sure no procedure is in progress
- Touch the **SET** key for 4 s: the display will show “PA”
- Touch the **SET**
- Touch the \wedge or \vee key within 15 s to set the value determined with the “PAS” parameter (the parameter is set at “-19” by default)
- Touch the **SET** or do not operate for 15 s: the display will show “SP”

To select a parameter:

- Touch the \wedge or \vee key

To set a parameter:

- Touch the **SET** key
- Touch the \wedge or \vee key within 15 s.
- Touch the **SET** key or do not operate for 15 s.

To exit the procedure:

- Touch the **SET** key for 4 s or do not operate for 60 s (any changes will be saved)

Parametri di configurazione

LABEL	MIN.	MAS.	U.M.	WORKING SETPOINT
SP	r1	r2	°C/°F (1)	working setpoint; see also r0 and r12

LABEL	MIN.	MAS.	U.M.	ANALOG INPUTS
CA1	-25	25	°C/°F (1)	room probe offset
CA2	-25	25	°C/°F (1)	if P4 = 1, evaporator probe offset if P4 = 2, condenser probe offset
P0	0	1	-	probe type (0 = PTC; 1 = NTC)
P1	0	1	-	degree Celsius decimal point (during normal operation) 1 = YES
P2	0	1	-	unit of measurement for temperature (2) 0 = °C (Celsius degree; resolution depends on P1 parameter) 1 = °F (Fahrenheit degree; resolution is 1 °F)
P4	0	2	-	second input function 0 = digital input (door switch or multifunction) 1 = analog input (evaporator probe) 2 = analog input (condenser probe)
P5	0	2	-	magnitude displayed during normal operation 0 = room temperature 1 = working setpoint 2 = if P4 = 0, “- -”

				if P4 = 1, evaporator temperature if P4 = 2, condenser temperature
P8	0	250	0,1s	delayed display of temperature changes as detected by the probes

LABEL	MIN.	MAS.	U.M.	MAIN REGULATOR
r0	0.1	15	°C/°F (1)	working setpoint differential; see also r12
r1	-99	r2	°C/°F (1)	minimum working setpoint
r2	r1	99	°C/°F (1)	maximum working setpoint
r4	0	99	°C/°F (1)	working setpoint increase during the "energy saving" function; see also i0, i10 and HE2
r5	0	1	-	cooling or heating operation (3) 0 = cooling 1 = heating
r12	0	1	-	working setpoint differential type 0 = asymmetric 1 = symmetric

LABEL	MIN.	MAS.	U.M.	COMPRESSOR PROTECTION SYSTEM
C0	0	240	min	delay in switching on of compressor after the device switches on (4)
C2	0	240	min	minimum compressor switch-off duration (5)
C3	0	240	s	minimum duration of compressor switch on time
C4	0	240	min	duration of compressor switch off time during a room temperature probe error (code "Pr1"); see also C5
C5	0	240	min	duration of compressor switch on time during a room temperature probe error (code "Pr1"); see also C4
C6	0	199	°C/°F (1)	condenser temperature is higher than that at which the condenser overheating alarm is activated (code "COH") (6)
C7	0	199	°C/°F (1)	condenser temperature above which the compressor shut down alarm is activated (code "CSd")
C8	0	15	min	compressor shut down alarm delay (code "CSd") (7)

LABEL	MIN.	MAS.	U.M.	DEFROST
d0	0	99	h	if d8 = 0, 1 or 2, defrost interval 0 = interval defrost will never be activated if d8 = 3, maximum defrost interval
d2	-99	99	°C/°F (1)	evaporator temperature at end of defrost; see also d3
d3	0	99	min	if P4 = 0 or 2, defrost duration if P4 = 1, maximum defrost duration; see also d2 0 = defrost will not be activated
d4	0	1	-	defrost when device is switched on (4) 1 = YES
d5	0	99	min	if d4 = 0, minimum time between switching on of device and activation of defrost (4) if d4 = 1, delay in activation of defrost after device is switched on (4)
d6	0	2	-	temperature displayed during defrost (only if P5 = 0) 0 = room temperature 1 = if on activation of defrost, the room temperature is below the "work setpoint + Δt", at maximum "work setpoint + Δt"; if on activation of defrost, the room temperature is above "work setpoint + Δt", at maximum the room temperature on activation of defrost (8) (9) 2 = label "dEF"
d7	0	15	min	dripping duration (during dripping the compressor will remain switched off)
d8	0	3	-	defrost activation methods 0 = AT INTERVALS - FOR TIME - defrost will be activated once the device has altogether been running for time d0 1 = AT INTERVALS - FOR COMPRESSOR SWITCH-ON - defrost will be activated once the compressor has altogether been switched on for time d0 2 = AT INTERVALS - FOR EVAPORATOR TEMPERATURE - defrost will be activated when the evaporator temperature has remained below the temperature d9 for a total time of d0 (10) 3 = ADAPTIVE - defrost will be activated at intervals, whose duration will each time depend on the duration of compressor switch-ons, the evaporator temperature and the door switch input activation; see also d18, d19, d20, d22, i13 and i14 (10)
d9	-99	99	°C/°F (1)	evaporator temperature is higher than that at which the defrost interval counter is suspended (only if d8 = 2)
d11	0	1	-	defrost alarm switches off once maximum time limit has been reached (code "dFd"); only if P4 = 1 and in absence of evaporator probe error (code "Pr2") 1 = YES
d16	0	999	min	defrost interval (defrost will be activated when the compressor has been on totally, with the evaporator temperature below that of d22, for time d18; only if d8 = 3) 0 = defrost will never be activated due to the effect of this condition
d18	0	999	min	defrost interval (defrost will be activated when the compressor has been on totally, with the evap. temp. below that of d22, for time d18; only if d8 = 3) 0 = defrost will never be activated due to the effect of this condition
d19	0	40	°C/°F (1)	evaporator temperature below which the defrost is activated (relative to the evaporator temperatures average, or "evaporator temperatures average - d19"; only if d8 = 3)
d20	0	999	min	minimum consecutive time the compressor must be switched on such as to provoke the defrost activation 0 = defrost will never be activated due to the effect of this condition
d22	0	19,9	°C/°F (1)	evaporator temperature above which the defrost interval count shall be suspended (relating to the average of evaporator temperatures, that is to say, "evaporator temperatures average + d22"; only if d8 = 3); see also d18

LABEL	MIN.	MAS.	U.M.	TEMPERATURE ALARMS (11) (12)
A1	0	99	°C/°F (1)	room temperature below which the minimum temperature alarm is triggered (code "AL"; it concerns the working setpoint, that is to say, "working setpoint - A1"); see also A11 0 = alarm absent
A4	0	99	°C/°F (1)	room temperature above which the maximum temperature alarm is triggered (code "AH"; it concerns the working setpoint, that is to say, "working setpoint + A4"); see also A11 0 = alarm absent
A6	0	99	10 min	delay in maximum temperature alarm (code "AH") after the device is switched on (4)
A7	0	199	min	minimum temperature alarm delay (code "AL") and maximum temperature alarm delay (code "AH")
A11	0,1	15	°C/°F (1)	differential of A1 and A4 parameters

LABEL	MIN.	MAS.	U.M.	DIGITAL INPUTS
i0	0	4	-	effect caused by the activation of the digital input 0 = no effect 1 = DOOR SWITCH - DOOR SWITCH INPUT ALARM ACTIVATION (code "id") - the compressor will be switched off (at maximum for time i3 or until the input is deactivated); see also i2 (13) 2 = MULTIFUNCTION - ACTIVATION OF "ENERGY SAVING" FUNCTION – the "energy saving" function will be activated (just with effect on the compressor, until the input is deactivated); see also r4 3 = MULTIFUNCTION - ACTIVATION OF MULTIFUNCTION INPUT ALARM (code "iA") - the device will continue to operate normally; see also i2 4 = MULTIFUNCTION - ACTIVATION OF THE MAXIMUM PRESSURE SWITCH ALARM (code "iA") - the compressor will be switched off (until the input is deactivated); see also i2
i1	0	1	-	type of digital input contact 0 = normally open (active input with closed contact) 1 = normally closed (active input with open contact)
i2	-1	120	min	if i0 = 1, delay in signalling of door switch input alarm (code "id") -1 = the alarm will not be signalled if i0 = 3, delay in signalling of multifunction input alarm (code "iA") -1 = the alarm will not be signalled if i0 = 4, delay in switching on of compressor after the deactivation of the maximum pressure switch alarm (code "iA") -1 = reserved
i3	-1	120	min	maximum duration of the effect caused by the activation of the door switch input on the compressor -1 = the effect will last until the input is deactivated
i10	0	999	min	time that must pass in absence of door switch input activations (after the room temperature has reached the working setpoint) for the "energy saving" function to be activated; see also r4 and HE2 0 = the function will never be activated due to the effect of this condition
i13	0	240	-	number of door switch input activations such as to provoke the defrost activation 0 = defrost will never be activated due to the effect of this condition
i14	0	240	min	minimum duration of the door switch input activation such as to provoke the defrost activation 0 = defrost will never be activated due to the effect of this condition





LABEL	MIN.	MAS.	U.M.	ENERGY SAVING
HE2	0	99	min	maximum duration of the "energy saving" function activated due to the effect of absence of door switch input activation; see also r4 and i10 0 = the function will last until the input is activated
HE3	0	240	min	time interval with no key strokes, after which the "low consumption" function is activated 0 = the mode shall never be aac

LABEL	MIN.	MAS.	U.M.	VARIOUS
POF	0	1	-	⏸ key activation 1 = YES
PAS	-99	999	-	access password for the configuration parameters 0 = the password need not be set

- (1) the unit of measurement depends on P2
(2) properly set the parameters corresponding to the regulators after setting P2 parameter
(3) if r5 parameter is set at 1, the "energy saving" function and the defrost management will be switched off
(4) the parameter has effect even after an interruption in the power supply that occurs while the device is switched on
(5) the time set by parameter C2 is counted also when the device is off
(6) the differential of parameter is 2.0°C/4°F
(7) if when the device is switched on, the condenser temperature is already above that established in C7 parameter, then C8 parameter will not have effect
(8) the value Δt depends on r12 parameter (r0 if r12 = 0, r0/2 if r12 = 1)
(9) the display restores normal operation when, at the end of the dripping phase, room temperature falls below the value that locked the display (or if a temperature alarm is triggered)
(10) if P4 parameter is set at 0 or 2, the device will function as if d8 parameter were set at 0
(11) during defrost and dripping, the maximum temperature alarm is absent, provided that it was triggered after defrost activation.
(12) during activation of the door switch input, the maximum temperature alarm is absent, provided the alarm was signaled after the activation of the input
(13) the compressor is switched off 10 s after the activation of the input

POSITIVE TEMPERATURE "-2/+8°C"

Setting the working setpoint

- Make sure that the keyboard is not locked and that no procedure is in progress
- Touch the **SET** key: the LED  will flash
- Touch the  or  key within 15 s; see also r1 and r2 parameters
- Touch the **SET** key or do not operate for 15 s: the LED  will switch off after which, the device will exit the procedure.

To exit the procedure before the operation is complete:

- Touch the  (any changes will not be saved)

The working setpoint can also be set via **SP** parameter.

Working setpoints

LABEL	MIN.	MAS.	U.M.	WORKING SETPOINT
r1	r2		°C/°F (1)	working setpoint; see also r0 and r12

Setting the configuration parameters

To access the procedure:

- Make sure no procedure is in progress
- Touch the **SET** key for 4 s: the display will show "PA"
- Touch the **SET**

- Touch the \wedge or \vee key within 15 s to set the value determined with the "PAS" parameter (the parameter is set at "-19" by default)
- Touch the **SET** or do not operate for 15 s: the display will show "SP"

To select a parameter:

- Touch the \wedge or \vee key

To set a parameter:

- Touch the **SET** key
- Touch the \wedge or \vee key within 15 s.
- Touch the **SET** key or do not operate for 15 s.

To exit the procedure:

- Touch the **SET** key for 4 s or do not operate for 60 s (any changes will be saved)

Parametri di configurazione

LABEL	MIN.	MAS.	U.M.	WORKING SETPOINT
SP	r1	r2	°C/°F (1)	working setpoint; see also r0 and r12

LABEL	MIN.	MAS.	U.M.	ANALOG INPUTS
CA1	-25	25	°C/°F (1)	room probe offset
CA2	-25	25	°C/°F (1)	if P4 = 1 or 2, evaporator probe offset; if P4 = 3, condenser probe offset
P0	0	1	-	probe type (0 = PTC; 1 = NTC)
P1	0	1	-	degree Celsius decimal point (during normal operation) 1 = YES
P2	0	1	-	unit of measurement for temperature (2) 0 = °C (Celsius degree; resolution depends on P1 parameter) 1 = °F (Fahrenheit degree; resolution is 1 °F)
P4	0	3	-	second analog input function 0 = absent 1 = evaporator probe (defrost probe and probe determining the activity of the evaporator fan) 2 = evaporator probe (probe determining the activity of the evaporator fan) 3 = condenser probe
P5	0	4	-	magnitude displayed during normal operation 0 = room temperature 1 = working setpoint 2 = if P4 = 0, "- - -" if P4 = 1 or 2, evaporator temperature if P4 = 3, condenser temperature
P8	0	250	0,1 s	delayed display of temperature changes as detected by the probes

LABEL	MIN.	MAS.	U.M.	MAIN REGULATOR
r0	0.1	15	°C/°F (1)	working setpoint differential; see also r12
r1	-99	r2	°C/°F (1)	minimum working setpoint
r2	r1	199	°C/°F (1)	maximum working setpoint
r4	0	99	°C/°F (1)	working setpoint increase during the "energy saving" function; see also i0, i10 and HE2
r5	0	1	-	cooling or heating operation (3) 0 = cooling 1 = heating
r12	0	1	-	working setpoint differential type 0 = asymmetric 1 = symmetric

LABEL	MIN.	MAS.	U.M.	COMPRESSOR PROTECTION SYSTEM
C0	0	240	min	delay in switching on of compressor after the device switches on (4)
C2	0	240	min	minimum compressor switch-off duration (5)
C3	0	240	s	minimum duration of compressor switch on time
C4	0	240	min	duration of compressor switch off time during a room temperature probe error (code "Pr1"); see also C5
C5	0	240	min	duration of compressor switch on time during a room temperature probe error (code "Pr1"); see also C4
C6	0	199	°C/°F (1)	condenser temperature is higher than that at which the condenser overheating alarm is activated (code "COH") (6)
C7	0	199	°C/°F (1)	condenser temperature above which the compressor shut down alarm is activated (code "CSd")
C8	0	15	min	compressor shut down alarm delay (code "CSd") (7)
C10	0	999	10 h	compressor operation hours to signal service for compressor is required 0 = function disables

LABEL	MIN.	MAS.	U.M.	DEFROST
d0	0	99	h	if d8 = 0, 1 or 2, defrost interval 0 = interval defrost will never be activated if d8 = 3, maximum defrost interval
d1	0	2	-	type of defrost 0 = ELECTRIC - during defrost the compressor will remain off and the defrost output will be activated; evaporator fan activity will depend on F2 parameter 1 = BY HOT GAS - during defrost the compressor will be switched on and the defrost output will be activated; evaporator fan activity will depend on F2 parameter 2 = VIA STOPPING OF COMPRESSOR - during defrost the compressor will remain switched off and the defrost output will remain deactivated; evaporator fan activity will depend on F2 parameter
d2	-99	99	°C/°F (1)	evaporator temperature at end of defrost; see also d3
d3	0	99	min	if P4 = 0, 2 or 3, defrost duration if P4 = 1, maximum defrost duration; see also d2 0 = defrost will not be activated
d4	0	1	-	defrost when device is switched on (4)

				1 = YES
d5	0	99	min	if d4 = 0, minimum time between switching on of device and activation of defrost (4) if d4 = 1, delay in activation of defrost after device is switched on (4)
d6	0	2	-	temperature displayed during defrost (only if P5 = 0) 0 = room temperature 1 = if on activation of defrost, the room temperature is below the "work setpoint + Δt ", at maximum "work setpoint + Δt "; if on activation of defrost, the room temperature is above "work setpoint + Δt ", at maximum the room temperature on activation of defrost (8) (9) 2 = label "dEF"
d7	0	15	min	dripping duration (during dripping the compressor will remain switched off and the defrost output will remain deactivated; evaporator fan activity will depend on F2 parameter)
d8	0	3	-	defrost activation methods 0 = AT INTERVALS - FOR TIME - defrost will be activated once the device has altogether been running for time d0 1 = AT INTERVALS - FOR COMPRESSOR SWITCH-ON - defrost will be activated once the compressor has altogether been switched on for time d0 2 = AT INTERVALS - FOR EVAPORATOR TEMPERATURE - defrost will be activated when the evaporator temperature has remained below the temperature d9 for a total time of d0 (10) 3 = ADAPTIVE - defrost will be activated at intervals, whose duration will each time depend on the duration of compressor switch-ons, the evaporator temperature and the door switch input activation; see also d18, d19, d20, d22, i13 and i14 (10)
d9	-99	99	°C/°F (1)	evaporator temperature is higher than that at which the defrost interval counter is suspended (only if d8 = 2)
d11	0	1	-	defrost alarm switches off once maximum time limit has been reached (code "dFd"; only if P4 = 1 and in absence of evaporator probe error (code "Pr2") 1 = YES
d15	0	99	min	minimum time that the compressor must be switched on before defrost can be activated (only if d1 = 1) (11)
d18	0	999	min	defrost interval (defrost will be activated when the compressor has been on totally, with the evap. temp. below that of d22, for time d18; only if d8 = 3) 0 = defrost will never be activated due to the effect of this condition
d19	0	40	°C/°F (1)	evaporator temperature below which the defrost is activated (relative to the evaporator temperatures average, or "evaporator temperatures average - d19"; only if d8 = 3)
d20	0	999	min	minimum consecutive time the compressor must be switched on such as to provoke the defrost activation 0 = defrost will never be activated due to the effect of this condition
d22	0	19,9	°C/°F (1)	evaporator temperature above which the defrost interval count shall be suspended (relating to the average of evaporator temperatures, that is to say, "evaporator temperatures average + d22"; only if d8 = 3); see also d18

LABEL	MIN.	MAS.	U.M.	TEMPERATURE ALARMS
A1	0	99	°C/°F (1)	room temperature below which the minimum temperature alarm is triggered (code "AL"; it concerns the working setpoint, that is to say, "working setpoint - A1"); see also A11 0 = alarm absent
A4	0	99	°C/°F (1)	room temperature above which the maximum temperature alarm is triggered (code "AH"; it concerns the working setpoint, that is to say, "working setpoint + A4"); see also A11 0 = alarm absent
A6	0	99	10 min	delay in maximum temperature alarm (code "AH") after the device is switched on (4)
A7	0	240	min	minimum temperature alarm delay (code "AL") and maximum temperature alarm delay (code "AH")
A8	0	240	min	delay in maximum temperature alarm (code "AH") from the conclusion of evaporator fan standstill (12)
A9	0	240	min	delay in maximum temperature alarm (code "AH") following the deactivation of the door switch input (13)
A11	0,1	15	°C/°F (1)	differential of A1 and A4 parameters

LABEL	MIN.	MAS.	U.M.	EVAPORATOR FAN
F0	0	4	-	evaporator fan activity during normal operation 0 = switched off 1 = switched on; see also F4, F5, i10 and HE2 (14) 2 = with F1 and F10 satisfied: - on if compressor on - depending on F7 and F8 if compressor off see also F4, F5, i10 and HE2 (15) 3 = depending on F1; see also F4, F5, i10 and HE2 (16) (17) 4 = switched off if the compressor is switched off, depending on F1 if the compressor is switched on; see also F4, F5, i10 and HE2 (16) (18)
F1	-99	99	°C/°F (1)	evaporator temperature above (if r5 = 0) or below (if r5 = 1) which the evaporator fan is switched off (only if F0 = 2, 3 or 4) (6)
F2	0	2	-	evaporator fan activity during defrost and dripping 0 = switched off 1 = switched on 2 = depending on F0
F3	0	15	min	duration of evaporator fan standstill (during evaporator fan deactivation the compressor can be switched on, the defrost output will remain deactivated and the evaporator fan will remain switched off)
F4	0	240	10 s	duration of evaporator fan switch off during "energy saving" function; see also F5, i10 and HE2
F5	0	240	10 s	duration of evaporator fan switch on during "energy saving" function; see also F4, i10 and HE2
F7	0	240	s	time the evaporator fan is switched off when the compressor is switched off; also look at F8 (only if F0 = 2)
F8	0	240	s	time the evaporator fan is switched on when the compressor is switched off; also look at F7 (only if F0 = 2)
F9	0	240	s	evaporator fan switch off delay since the compressor switches off (only if F0 = 2)
F10	0	99	°C/°F (1)	difference "room temperature - evaporator temperature" over which the evaporator fan is forced on (0 = disabled)

LABEL	MIN.	MAS.	U.M.	DIGITAL INPUTS
i0	0	5	-	effect caused by the activation of the digital input 0 = no effect 1 = DOOR SWITCH - DOOR SWITCH INPUT ALARM ACTIVATION (code "id") - the compressor and the evaporator fan will be switched off, the buzzer will be activated (at maximum for time i3 or until the

				input is deactivated); see also i2 (19) 2 = DOOR SWITCH - DOOR SWITCH INPUT ALARM ACTIVATION (code "id") - the evaporator fan will be switched off, the buzzer will be activated (at maximum for time i3 or until the input is deactivated); see also i2 3 = MULTIFUNCTION - ACTIVATION OF "ENERGY SAVING" FUNCTION - the "energy saving" function will be activated (just with effect on the compressor, until the input is deactivated); see also r4 4 = MULTIFUNCTION - ACTIVATION OF MULTIFUNCTION INPUT ALARM (code "iA") - the buzzer will be activated; see also i2 5 = MULTIFUNCTION - ACTIVATION OF THE MAXIMUM PRESSURE SWITCH ALARM (code "iA") - the compressor will be switched off, the buzzer will be activated (until the input is deactivated); see also i2
I1	0	1	-	type of digital input contact 0 = normally open (active input with closed contact) 1 = normally closed (active input with open contact)
I2	-1	120	min	if i0 = 1 or 2, delay in signalling of door switch input alarm (code "id") -1 = the alarm will not be signalled if i0 = 4, delay in signalling of multifunction input alarm (code "iA") -1 = the alarm will not be signalled if i0 = 5, delay in switching on of compressor after the deactivation of the maximum pressure switch alarm (code "iA") -1 = reserved
I3	-1	120	min	maximum duration of the effect caused by the activation of the door switch input on the compressor -1 = the effect will last until the input is deactivated
I10	0	999	min	time that must pass in absence of door switch input activations (after the room temperature has reached the working setpoint) for the "energy saving" function to be activated; see also r4, F4, F5 and HE2 0 = the function will never be activated due to the effect of this condition
I13	0	240	-	number of door switch input activations such as to provoke the defrost activation 0 = defrost will never be activated due to the effect of this condition
I14	0	240	min	minimum duration of the door switch input activation such as to provoke the defrost activation 0 = defrost will never be activated due to the effect of this condition







LABEL	MIN.	MAS.	U.M.	ENERGY SAVING
HE2	0	999	min	maximum duration of the "energy saving" function activated due to the effect of absence of door switch input activation; see also r4, F4, F5 and i10 0 = the function will last until the input is activated
HE3	0	240	min	time interval with no key strokes, after which the "low consumption" function is activated 0 = the mode shall never be activated

LABEL	MIN.	MAS.	U.M.	VARIOUS
POF	0	1	-	key activation  (1 = YES)
PAS	-99	999	min	access password for the configuration parameters 0 = the password need not be set

- (1) the unit of measurement depends on P2
- (2) properly set the parameters corresponding to the regulators after setting P2 parameter
- (3) if r5 parameter is set at 1, the "energy saving" function and the defrost management will be switched off; see also F1 parameter
- (4) the parameter has effect even after an interruption in the power supply that occurs while the device is switched on
- (5) the time set by parameter C2 is counted also when the device is off
- (6) the differential of parameter is 2.0°C/4°F
- (7) if when the device is switched on, the condenser temperature is already above that established in C7 parameter, then C8 parameter will not have effect
- (8) the value Δt depends on r12 parameter (r0 if r12 = 0, r0/2 if r12 = 1)
- (9) the display restores normal operation when, at the end of the dripping phase, room temperature falls below the value that locked the display (or if a temperature alarm is triggered)
- (10) if P4 parameter is set at 0, 2 or 3, the device will function as if d8 parameter were set at 0
- (11) if when defrost is activated, the operating duration of the compressor is less than the time established with d15 parameter, the compressor will remain on for the amount of time necessary to complete defrost, then the defrost shall be activated
- (12) during defrost, dripping and evaporator fan standstill, the maximum temperature alarm is absent, provided that it was triggered after defrost activation.
- (13) during activation of the door switch input, the maximum temperature alarm is absent, provided the alarm was signaled after the activation of the input
- (14) F4 and F5 parameters have effect when the compressor is off
- (15) F4 and F5 parameters have effect when the compressor is on
- (16) if P4 parameter is set at 2, the device will function as if F0 parameter were set at 2
- (17) F4 and F5 parameters have effect when the evaporator temperature is below the temperature established with F1 parameter
- (18) F4 and F5 parameters have effect when the compressor is on and the temperature of the evaporator is below the temperature established with F1 parameter
- (19) the compressor is switched off 10 s after the activation of the input; if the input is activated during defrost or when the evaporator fan is deactivated, the activation will not have any effect on the compressor.

NEGATIVE TEMPERATURE "-20/-10°C" ÷ "-24/-12°C"

Setting the working setpoint

- Make sure that the keyboard is not locked and that no procedure is in progress
- Touch the  **SET** key: the LED  will flash
- Touch the  or  key within 15 s; see also r1 and r2 parameters
- Touch the  **SET** key or do not operate for 15 s: the LED  will switch off after which, the device will exit the procedure.

To exit the procedure before the operation is complete:

- Touch the  (any changes will not be saved)

The working setpoint can also be set via **SP** parameter.

Working setpoints

LABEL	MIN.	MAS.	U.M.	WORKING SETPOINT
	r1	r2	°C/°F (1)	working setpoint; see also r0 and r12

Setting the configuration parameters

To access the procedure:

- Make sure no procedure is in progress
- Touch the **SET** key for 4 s: the display will show "PA"
- Touch the **SET**
- Touch the \wedge or \vee key within 15 s to set the value determined with the "PAS" parameter (the parameter is set at "-19" by default)
- Touch the **SET** or do not operate for 15 s: the display will show "SP"

To select a parameter:

- Touch the \wedge or \vee key

To set a parameter:

- Touch the **SET** key
- Touch the \wedge or \vee key within 15 s.
- Touch the **SET** key or do not operate for 15 s.

To exit the procedure:

- Touch the **SET** key for 4 s or do not operate for 60 s (any changes will be saved)

Parametri di configurazione

LABEL	MIN.	MAS.	U.M.	WORKING SETPOINT
SP	r1	r2	°C/°F (1)	working setpoint; see also r0 and r12

LABEL	MIN.	MAS.	U.M.	WORKING SETPOINT
CA1	-25	25	°C/°F (1)	if P4 = 0, 1 or 2, room probe offset if P4 = 3, incoming air probe offset
CA2	-25	25	°C/°F (1)	evaporator probe offset
CA3	-25	25	°C/°F (1)	if P4 = 1, condenser probe offset if P4 = 2, critical temperature probe offset if P4 = 3, outgoing air probe offset
P0	0	1	-	probe type 0 = PTC 1 = NTC
P1	0	1	-	degree Celsius decimal point (during normal operation) 1 = YES
P2	0	1	-	unit of measurement for temperature (2) 0 = °C (Celsius degree; resolution depends on P1 parameter) 1 = °F (Fahrenheit degree; resolution is 1 °F)
P3	0	2	-	evaporator probe function 0 = absent probe 1 = defrost probe and probe determining the activity of the evaporator fan 2 = probe determining the activity of the evaporator fan
P4	0	3	-	fourth inlet function 0 = multifunction input (digital input) 1 = condenser probe (analog input) 2 = critical temperature probe (analog input) 3 = outlet air probe (analog input) (3)
P5	0	4	-	magnitude displayed during normal operation 0 = if P4 = 0, 1 or 2, room temperature if P4 = 3, CPT temperature 1 = working setpoint 2 = evaporator temperature 3 = if P4 = 0, "- -" if P4 = 1, condenser temperature if P4 = 2, critical temperature if P4 = 3, outlet air temperature 4 = if P4 = 0, 1 o 2, "- -" if P4 = 3, inlet air temperature
P7	0	100	%	inflowing air temperature percentage for the calculation of the CPT temperature
P8	0	250	0,1 s	delayed display of temperature changes as detected by the probes

LABEL	MIN.	MAS.	U.M.	MAIN REGULATOR
r0	0.1	15	°C/°F (1)	working setpoint differential; see also r12
r1	-99	r2	°C/°F (1)	minimum working setpoint
r2	r1	99	°C/°F (1)	maximum working setpoint
r4	0	99	°C/°F (1)	working setpoint increase during the "energy saving" function; see also i5, i10 and HE2
r5	0	1	-	cooling or heating operation (4) 0 = cooling 1 = heat
r6	0	99	°C/°F (1)	if r5 = 0, working setpoint decrease during the "rapid cooling" function (only if r8 = 1); see also r7 if r5 = 1, working setpoint increase during the "rapid heating" function (only if r8 = 1); see also r7
r7	0	240	min	if r5 = 0, "rapid cooling" function duration (only if r8 = 1); see also r6 if r5 = 1, "rapid heating" function duration (only if r8 = 1); see also r6
r8	0	2	-	this function can be enabled/disabled with the key FNC \vee 0 = none 1 = if r5 = 0, "Rapid cooling" function if r5 = 1, "Rapid heating" function 2 = "energy saving" function (only if r5 = 0)

r12	0	1	-	working setpoint differential type 0 = asymmetric 1 = symmetric
-----	---	---	---	---

LABEL	MIN.	MAS.	U.M.	COMPRESSOR PROTECTION SYSTEM
C0	0	240	min	delay in switching on of compressor after the device switches on (5)
C2	0	240	min	minimum compressor switch-off duration (6)
C3	0	240	s	minimum duration of compressor switch on time
C4	0	240	min	duration of compressor switch off time during a room temperature probe error or inlet air probe error (code "Pr1"); see also C5
C5	0	240	min	duration of compressor switch on time during a room temperature probe error or inlet air probe error (code "Pr1"); see also C4
C6	0	200	°C/°F (1)	condenser temperature is higher than that at which the condenser overheating alarm is activated (code "COH") (7)
C7	0	200	°C/°F (1)	condenser temperature above which the compressor shut down alarm is activated (code "CSd")
C8	0	15	min	compressor shut down alarm delay (code "CSd") (8)
C10	0	9999	h	number of compressor operation hours above which the request for maintenance is triggered 0 = the request shall never be tri

LABEL	MIN.	MAS.	U.M.	DEFROST
d0	0	99	h	if d8 = 0, 1 or 2, defrost interval 0 = interval defrost will never be activated if d8 = 3, maximum defrost interval
d1	0	2	-	type of defrost 0 = ELECTRIC - during defrost the compressor will remain off and the defrost output will be activated; evaporator fan activity will depend on F2 parameter 1 = BY HOT GAS - during defrost the compressor will be switched on and the defrost output will be activated; evaporator fan activity will depend on F2 parameter 2 = VIA STOPPING OF COMPRESSOR - during defrost the compressor will remain switched off and the defrost output will remain deactivated; evaporator fan activity will depend on F2 parameter
d2	-99	99	°C/°F (1)	evaporator temperature at end of defrost; see also d3
d3	0	99	min	if P3 = 0 or 2, defrost duration if P3 = 1, maximum defrost duration; see also d2 0 = defrost will not be activated
d4	0	1	-	defrost when device is switched on (5) 1 = YES
d5	0	99	min	if d4 = 0, minimum time between switching on of device and activation of defrost (5) if d4 = 1, delay in activation of defrost after device is switched on (5)
d6	0	2	-	magnitude displayed during defrost (only if P5 = 0) 0 = room temperature or CPT temperature 1 = if on activation of defrost, the room temperature or CPT temperature is below the "work setpoint + Δt", at maximum "work setpoint + Δt"; if on activation of defrost, the room temperature or CPT temperature is above "work setpoint + Δt", at maximum the room temperature or CPT temperature on activation of defrost (9) (10) 2 = label "dEF"
d7	0	15	min	dripping duration (during dripping the compressor will remain switched off and the defrost output will remain deactivated; if d16 = 0, evaporator fan activity will depend on F2 parameter); if d16 ≠ 0, the evaporator fan shall remain off)
d8	0	3	-	defrost activation methods 0 = AT INTERVALS - FOR TIME - defrost will be activated once the device has altogether been running for time d0 1 = AT INTERVALS - FOR COMPRESSOR SWITCH-ON - defrost will be activated once the compressor has altogether been switched on for time d0 2 = AT INTERVALS - FOR EVAPORATOR TEMPERATURE - defrost will be activated when the evaporator temperature has remained below the temperature d9 for a total time of d0 (11) 3 = ADAPTIVE - defrost will be activated at intervals, whose duration will each time depend on the duration of compressor switch-ons, the evaporator temperature and the door switch input activation; see also d18, d19, d20, d22, i13 and i14 (11)
d9	-99	99	°C/°F (1)	evaporator temperature is higher than that at which the defrost interval counter is suspended (only if d8 = 2)
d11	0	1	-	defrost alarm switches off once maximum time limit has been reached (code "dFd"); only if P3 = 1 and in absence of evaporator probe error (code "Pr2") 1 = YES
d15	0	99	min	minimum time that the compressor must be switched on before defrost can be activated (only if d1 = 1) (12)
d16	0	99	min	pre-dripping duration (during dripping the compressor will remain switched off, the defrost output will be activated and the evaporator fan shall remain off)
d18	0	999	min	defrost interval (defrost will be activated when the compressor has been on totally, with the evaporator temperature below that of d22, for time d18; only if d8 = 3) 0 = defrost will never be activated due to the effect of this condition
d19	0	40	°C/°F (1)	evaporator temperature below which the defrost is activated (relative to the evaporator temperatures average, or "evaporator temperatures average - d19"; only if d8 = 3)
d20	0	999	min	minimum consecutive time the compressor must be switched on such as to provoke the defrost activation 0 = defrost will never be activated due to the effect of this condition
d21	0	500	min	minimum duration of compressor continuous operation from the switching on of the device (provided that the "cell temperature - working setpoint" or "CPT temperature - working setpoint" difference exceeds 10 °C/20 °F) and from the activation of the "rapid cooling" function so as to start the defrost 0 = defrost shall never be activated as a consequence of this condition
d22	0	19,9	°C/°F (1)	evaporator temperature above which the defrost interval count shall be suspended (relating to the average of evaporator temperatures, that is to say, "evaporator temperatures average + d22"; only if d8 = 3); see also d18

LABEL	MIN.	MAS.	U.M.	TEMPERATURE ALARMS
A1	0	99	°C/°F (1)	room temperature or CPT temperature below which the minimum temperature alarm is triggered (code "AL"; it concerns the working setpoint, that is to say, "working setpoint - A1"); see also A11 0 = alarm absent

A4	0	99	°C/°F (1)	room temperature or CPT temperature above which the maximum temperature alarm is triggered (code "AH"); it concerns the working setpoint, that is to say, "working setpoint + A4"; see also A11 0 = alarm absent
A6	0	99	10 min	delay in maximum temperature alarm (code "AH") after the device is switched on (5)
A7	0	240	min	minimum temperature alarm delay (code "AL") and maximum temperature alarm delay (code "AH")
A8	0	240	min	delay in maximum temperature alarm (code "AH") from the conclusion of evaporator fan standstill (13)
A9	0	240	min	delay in maximum temperature alarm (code "AH") following the deactivation of the door switch input (14)
A11	0,1	15	°C/°F (1)	differential of A1 and A4 parameters

LABEL	MIN.	MAS.	U.M.	EVAPORATOR FAN AND CONDENSATOR FAN
F0	0	4	-	evaporator fan activity during normal operation 0 = switched off 1 = switched on; see also F4, F5, i10 and HE2 (15) 2 = with F1 and F10 satisfied: - on if compressor on - depending on F7 and F8 if compressor off see also F4, F5, i10 and HE2 (16) 3 = depending on F1; see also F4, F5, i10 and HE2 (17) (18) 4 = switched off if the compressor is switched off, depending on F1 if the compressor is switched on; see also F4, F5, i10 and HE2 (17) (19)
F1	-99	99	°C/°F (1)	evaporator temperature above (if r5 = 0) or below (if r5 = 1) which the evaporator fan is switched off (only if F0 = 3 or 4) (7)
F2	0	2	-	evaporator fan activity during defrost and dripping 0 = switched off 1 = switched on 2 = depending on F0
F3	0	15	min	maximum duration of the evaporator fan stop; see also F7 (during the evaporator fan stop the compressor can remain on, the defrost outlet shall remain deactivated and the evaporator fan shall remain off)
F4	0	240	10 s	duration of the evaporator fan switch off during the "energy saving function"; see also F5, i5, i10 and HE2
F5	0	240	10 s	duration of the evaporator fan switch on during the "energy saving function"; see also F4, i5, i10 and HE2
F7	-99	99	°C/°F (1)	evaporator temperature below which the evaporator fan is restarted (in respect to the working setpoint, that is to say "working set-point + F7"); see also F3
F9	0	240	s	evaporator fan stop delay after the stop of the compressor (only if F0 = 2)
F10	0	99	°C/°F (1)	difference "room temperature - evaporator temperature" over which the evaporator fan is forced on (0 = disabled)
F11	0	99	°C/°F (1)	condenser temperature above which the condenser fan is switched on (7) (20) (21)
F12	0	240	s	condenser fan stop delay after the stop of the compressor
F15	0	240	s	duration of the evaporator fan stop when the compressor is turned off; see also F8 (only if F0 = 2)
F16	0	240	s	duration of the evaporator fan operation when the compressor is turned off; see also F7 (only if F0 = 2)

LABEL	MIN.	MAS.	U.M.	DIGITAL INPUTS
i0	0	5	-	effect caused by the activation of the door micro input; see also i2 0 = no effect 1 = COMPRESSOR AND EVAPORATOR FAN SWITCH-OFF - the compressor and evaporator fan will be switched off (for the duration of the i3 time max. or until the input is deactivated; in the latter case the evaporator fan shall be turned on 5 s after input deactivation) (22) 2 = EVAPORATOR FAN SWITCH-OFF - the evaporator fan shall be switched off (for the duration of the i3 time max. or until 5s after input deactivation) 3 = ROOM LIGHTING SWITCH-ON - the room lighting shall be switched on (until 10 s after input deactivation) 4 = COMPRESSOR AND EVAPORATOR FAN SWITCH-OFF AND ROOM LIGHTING SWITCH-ON - the compressor and evaporator fan will be switched off (for the duration of thr i3 time max. or until the input is deactivated; in the latter case the evaporator fan shall be turned on 5 s after the input deactivation) and the room lighting shall be switched on (until 10 s after input deactivation) (22) 5 = EVAPORATOR FAN SWITCH-OFF AND ROOM LIGHTING SWITCH-ON - the evaporator fan will be switched off (for the duration of the i3 time max. or until 5 s after input deactivation) and the room lighting shall be switched on (until 10 s after input deactivation) (22)
i1	0	1	-	type of door switch input contact 0 = normally open (active input with closed contact) 1 = normally closed (active input with open contact)
i2	-1	120	min	delay in signalling of door switch input alarm (code "id") -1 = the alarm will not be signalled
i3	-1	120	min	maximum duration of the effect caused by the activation of the door micro on the compressor and evaporator fan -1 = the effect shall last until the input is deactivated
i5	0	7	-	effect caused by the activation of the multifunction input 0 = no effect 1 = "ENERGY SAVING" FUNCTION ACTIVATION - the "energy saving" function shall be activated (until the input is deactivated), provided that the "rapid cooling" function is not in progress; see also r4 2 = MULTIFUNCTION INPUT ALARM ACTIVATION (code "iA") - the device shall continue working regularly; see also i7 3 = AUXILIARY OUTPUT SWITCH-ON - the auxiliary output shall be switched on (until the input is deactivated) 4 = DEVICE SWITCH-OFF - the device shall be switched off ("stand-by" mode, until the input is deactivated) 5 = COMPRESSOR THERMAL PROTECTION ALARM ACTIVATION (code "Cth") - the compressor shall be switched off (until the input is deactivated); see also i7 6 = GLOBAL THERMAL PROTECTION ALARM ACTIVATION (code "th") - all the utilities shall be switched off (until the input is deactivated and the device shall be switched off ("stand-by" mode) and switched back on or the power supply is cut); see also i7
i6	0	1	-	type of multifunction input contact 0 = normally open (active input with closed contact) 1 = normally closed (active input with open contact)

i7	0	120	min	if i5 = 2, delay in signalling of multifunction input alarm (code "iA") -1 = the alarm will not be signalled if i5 = 5 or 6, delay in switching on of compressor after the deactivation of the maximum pressure switch alarm (code "Cth") and after the deactivation of the global protection alarm (code "th") -1 = reserved
i10	0	999	min	time that must pass in absence of door switch input activations (after the room temperature or CPT temperature has reached the working setpoint) for the "energy saving" function to be activated; see also r4, F4, F5 and HE2 0 = the function will never be activated due to the effect of this condition
i13	0	240	-	number of door switch input activations such as to provoke the defrost activation 0 = defrost will never be activated due to the effect of this condition
i14	0	240	min	minimum duration of the door switch input activation such as to provoke the defrost activation 0 = defrost will never be activated due to the effect of this con
LABEL	MIN.	MAS.	U.M.	DIGITAL OUTPUTS
u1	0	7	-	utility managed through the K4 digital output (23) 0 = ROOM LIGHTING - see parameters i0 and u2 1 = DEMISTER HEATING ELEMENTS - see parameter u6 2 = AUXILIARY OUTPUT - see parameters i5 and u2 3 = ALARM OUTPUT 4 = NEUTRAL AREA OPERATION HEATING ELEMENTS - see parameter u7 6 = CONDENSER FAN - see parameters P4, F11 and F12 7 = ON/STAND-BY OUTPUT - see parameter POF
u2	0	1	-	room lighting switch on/off and auxiliary output enabling in manual mode when the device is switched off ("stand-by" mode) 1 = YES
u4	-	-	-	reserved
u5	-99	99	°C/°F (1)	room temperature or CPT temperature below which the door heating elements are switched on (7)
u6	1	120	min	duration of demister heating elements operation
u7	0	99	°C/°F (1)	room temperature or CPT temperature below which the neutral area operation heating elements are switched on (with regard to the working setpoint, that is to say, "working setpoint + u7") (7)

LABEL	MIN.	MAS.	U.M.	ENERGY SAVING
HE2	0	999	min	maximum duration of the "energy saving" function activated in manual mode due to the effect of absence of door micro switch input activation; see also r4, F4, F5 and i10 0 = the function will last until the input is activated
HE3	0	240	min	time interval with no key strokes, after which the "low consumption" function is activated 0 = the mode shall never be activated

LABEL	MIN.	MAS.	U.M.	VARIOUS
POF	0	1	-	 key activation 1 = YES
PAS	-99	999	-	access password for the configuration parameters 0 = the password need not be set

- (1) the unit of measurement depends on P2
(2) properly set the parameters corresponding to the regulators after setting P2 parameter
(3) the temperature associated with regulation and the temperature alarms is the CPT temperature; the formula to calculate the CPT temperature is as follows: CPT temperature = $\{[(\text{parameter P7}) \times (\text{inflowing air temperature})] + [((100 - \text{parameter P7}) \times (\text{outflowing air temperature}))]: 100\}$
(4) if r5 parameter is set at 1, the "energy saving" function and the defrost management will be switched off; see also F1 parameter
(5) the parameter has effect even after an interruption in the power supply that occurs while the device is switched on
(6) the time set by parameter C2 is counted also when the device is off ("stand-by" status)
(7) the differential of parameter is 2.0°C/4°F
(8) if when the device is switched on, the condenser temperature is already above that established in C7 parameter, then C8 parameter will not have effect
(9) the value Δt depends on r12 parameter (r0 if r12 = 0, r0/2 if r12 = 1)
(10) the display restores normal operation when, at the end of the dripping phase, room temperature or CPT temperature falls below the value that locked the display (or if a temperature alarm is triggered)
(11) if P3 parameter is set at 0 or 2, the device will function as if d8 parameter were set at 0
(12) if when defrost is activated, the operating duration of the compressor is less than the time established with d15 parameter, the compressor will remain on for the amount of time necessary to complete defrost, then the defrost shall be activated
(13) during defrost, dripping and evaporator fan standstill, the maximum temperature alarm is absent, provided that it was triggered after defrost activation.
(14) during activation of the door switch input, the maximum temperature alarm is absent, provided the alarm was signalled after the activation of the input
(15) F4 and F5 parameters have effect when the compressor is off
(16) F4 and F5 parameters have effect when the compressor is on
(17) if P3 parameter is set at 0, the device will function as if F0 parameter were set at 2
(18) F4 and F5 parameters have effect when the evaporator temperature is below the temperature established with F1 parameter
(19) F4 and F5 parameters have effect when the compressor is on and the temperature of the evaporator is below the temperature established with F1 parameter
(20) if the P4 parameter is set at 0, 2 or 3, the condenser fan shall work in parallel with the compressor
(21) the condenser fan is switched on provided that the compressor is switched on and is switched off when the condenser temperature falls below the value set with parameter F11 provided that the compressor is switched off
(22) the compressor is switched off 10 s after the activation of the input; if the input is activated during defrost or when the evaporator fan is deactivated, the activation will not have any effect on the compressor
(23) to avoid damaging the connected load, set the parameter when the device is switched off ("stand-by" status).

LOADING THE PRODUCT

- Now and not before it is possible to put the food to conserve into the refrigerator.
- Place the products into the cell uniformly to allow a good internal air circulation across the cell.
- Avoid obstructing the ventilation areas inside the refrigerator.
- Only load the top shelf up to the stacking mark.
- Do not place products below the bottom shelf support.
- Cover or wrap food before introducing it into the refrigerator and avoid introducing warm food or steaming liquids.
- Only leave the door open for the strict amount of time necessary to introduce or remove food

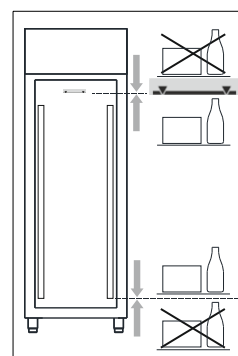

WARNING: If ambient conditions do not allow the evaporation of condense water through the automatic system, insert container on the external bottom part or convey water toward sewerage.

STOPPING

In any condition and for stopping the machine it is enough to press the main switch 1 in OFF position; the pilot light of the switch will go out.

WARNING: the main switch 1 DOES NOT insulate the machine from the electric current.

Set the general cut-out in OFF position.

To insulate the refrigerator from the electric current, remove the plug from the socket.

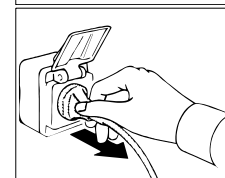
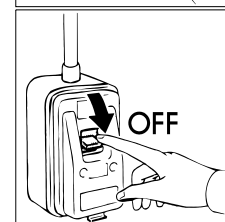
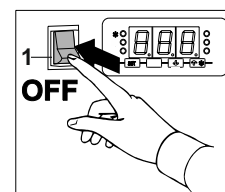

DEFROSTING

THE DEFROSTING OF THE REFRIGERATING CABINETS IS TOTALLY AUTOMATIC.

The air defrosting operation of the appliances at "POSITIVE TEMPERATURE 0/+10°C" occurs automatically every 6 hours. The defrosting lasts 20 minutes.

The defrosting of the installations with "POSITIVE TEMPERATURE -2/+8°C" and "NEGATIVE TEMPERATURE -20/-10°C" is with resistance and occurs automatically every 6 hours. The duration of the defrosting is automatically regulated by the refrigerator.

The defrosting of the installations with "NEGATIVE TEMPERATURE -24/-12°C" is hot gas and occurs automatically every 6 hours. The duration of the defrosting is automatically regulated by the refrigerator.



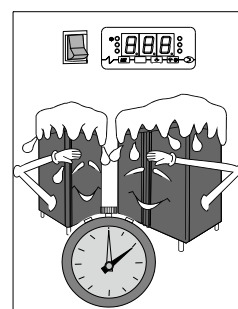

A defrost cycle can be selected at any time by pressing button "∧❄"; for 5 seconds. The next automatic defrost cycle will start 6 hours after pressing the button.



ALARMS AND SIGNALS

POSITIVE TEMPERATURE "0/+10°C"

Signals

LED	MEANING
	Compressor LED If the LED is on, the compressor is on If the LED is flashing: - the working setpoint is in the process of being set - a compressor protection will be in progress
	Defrost LED If the LED is on, defrost is in progress If the LED is flashing, dripping will be in progress
	Energy saving LED If the LED is on and the display is switched on, the "energy saving" function is in progress If the LED is on and the display is switched off, the "low consumption" function is in progress; touch a key to restore normal display
°C	Celsius degrees LED If the LED is on, the unit of measurement for temperature is Celsius degrees
°F	Fahrenheit degrees LED If the LED is on, the unit of measurement for temperature is Fahrenheit degrees
	LED on/stand-by If the LED is on, the device is switched off

Signals

CODE	MEANING
Loc	the keyboard is blocked
- - -	the operation requested is not available
dEF	defrost is in progress

Alarms

CODE	MEANING
AL	Minimum temperature alarm Solutions: - check the room temperature; see A1 parameter Main consequences: - the device will continue to operate normally
AH	Maximum temperature alarm Solutions: - check the room temperature; see A4 parameter Main consequences: - the device will continue to operate normally
id	Door switch input alarm Solutions: - check the causes of the activation of the input; see i0 and i1 parameters Main consequences: - the effect established with the i0 parameter
iA	Multifunction input alarm or pressure switch alarm Solutions: - check the causes of the activation of the input; see i0 and i1 parameters Main consequences: - the effect established with the i0 parameter
COH	Condenser overheated alarm Solutions: - check the condenser temperature; see C6 parameter Main consequences: - the device will continue to operate normally
Csd	Compressor shut down alarm Solutions: - check the condenser temperature; see C7 parameter - switch the device off and back on again: if when the device is switched back on, the temperature of the condenser is still higher than that established in C7 parameter, disconnect the power supply and clean the condenser Main consequences: - the compressor will be switched off

dFd	Defrost alarm switched off because maximum time has been reached Solutions: - check the integrity of the evaporator probe; see d2, d3 and d11 parameters - touch a key to restore normal display Main consequences: - the device will continue to operate normally
------------	--

When the cause of the alarm disappears, the device restores normal operation, except for the following alarms:

- compressor shut down alarm (code "CSd") which requires the switching off of the device or the temporary suspension of the power supply.
- defrost alarm switched off because maximum time has been reached (code "dFd") which requires the touching of a key







Errors

CODE	MEANING
Pr1	Room temperature probe error Solutions: - check that the probe is the PTC or NTC type; see P0 parameter - check the device-probe connection - check room temperature Main consequences: - compressor activity will depend on C4 and C5 parameters - the defrost will not be activated
Pr2	Evaporator probe or condenser probe error Solutions: - the same as in the previous example, but with regard to the evaporator probe or the condenser probe Main consequences: - if P4 parameter is set at 1, the defrost interval will last for the amount of time set with d3 parameter - if P4 parameter is set at 1 and d8 parameter is set at 2 or to 3, the device will operate as if d8 parameter were set at 0 - if P4 parameter is set at 2, the condenser overheated alarm (code "COH") will never be activated - if P4 parameter is set at 2, the compressor shut down alarm (code "CSd") will never be activated

When the cause of the error disappears, the device restores normal operation.

POSITIVE TEMPERATURE "-2/+8°C"

Signals

LED	MEANING
	Compressor LED If the LED is on, the compressor is on If the LED is flashing: - the working setpoint is in the process of being set - a compressor protection will be in progress
	Defrost LED If the LED is on, defrost is in progress If the LED is flashing: - defrost will be requested but a compressor protection will be in progress - dripping will be in progress - defrost will be requested but a compressor minimum switch-on shall be in progress
	Evaporator fan LED If the LED is on the evaporator fan will be on If the LED is flashing evaporator fan standstill will be in progress
	Energy saving LED If the LED is on and the display is switched on, the "energy saving" function is in progress If the LED is on and the display is switched off, the "low consumption" function is in progress; touch a key to restore normal display
	LED service If the LED is on, service for compressor will be required
°C	Celsius degrees LED If the LED is on, the unit of measurement for temperature is Celsius degrees
°F	Fahrenheit degrees LED If the LED is on, the unit of measurement for temperature is Fahrenheit degrees
	LED on/stand-by If the LED is on, the device is switched

Signals

CODE	MEANING
Loc	the keyboard is blocked
- - -	the operation requested is not available

dEF	defrost is in progress
------------	------------------------

Alarms

CODE	MEANING
AL	Minimum temperature alarm Solutions: - check the room temperature; see A1 parameter Main consequences: - the device will continue to operate normally
AH	Maximum temperature alarm Solutions: - check the room temperature; see A4 parameter Main consequences: - the device will continue to operate normally
id	Door switch input alarm Solutions: - check the causes of the activation of the input; see i0 and i1 parameters Main consequences: - the effect established with the i0 parameter
iA	Multifunction input alarm or pressure switch alarm Solutions: - check the causes of the activation of the input; see i0 and i1 parameters Main consequences: - the effect established with the i0 parameter
COH	Condenser overheated alarm Solutions: - check the condenser temperature; see C6 parameter Main consequences: - the device will continue to operate normally
CSd	Compressor shut down alarm Solutions: - check the condenser temperature; see C7 parameter - switch the device off and back on again: if when the device is switched back on, the temperature of the condenser is still higher than that established in C7 parameter, disconnect the power supply and clean the condenser Main consequences: - the compressor will be switched off
dFd	Defrost alarm switched off because maximum time has been reached Solutions: - check the integrity of the evaporator probe; see d2, d3 and d11 parameters - touch a key to restore normal display Main consequences: - the device will continue to operate normally

When the cause of the alarm disappears, the device restores normal operation, except for the following alarms:
- compressor shut down alarm (code "CSd") which requires the switching off of the device or the temporary suspension of the power supply
- defrost alarm switched off because maximum time has been reached (code "dFd") which requires the touching of a key.







Errors

CODE	MEANING
Pr1	Room temperature probe error Solutions: - check that the probe is the PTC or NTC type; see P0 parameter - check the device-probe connection - check room temperature Main consequences: - compressor activity will depend on C4 and C5 parameters - the defrost will not be activated
Pr2	Evaporator probe or condenser probe error Solutions: - the same as in the previous example, but with regard to the evaporator probe or the condenser probe Main consequences: - if P4 parameter is set at 1, the defrost interval will last for the amount of time set with d3 parameter - if P4 parameter is set at 1 and d8 parameter is set at 2 or to 3, the device will operate as if d8 parameter were set at 0 - if P4 parameter is set at 1 or 2 and F0 parameter is set at 3 to 4, the device will operate as if parameter were set at 2 - if P4 parameter is set at 3, the condenser overheated alarm (code "COH") will never be activated - if P4 parameter is set at 3, the compressor shut down alarm (code "CSd") will never be activated

When the cause of the error disappears, the device restores normal operation.

NEGATIVE TEMPERATURE “ -20/-10°C” ÷ “-24/-12°C”

Signals

LED	MEANING
	Compressor LED - If the LED is on, the compressor is on - If the LED is flashing: - the working setpoint is in the process of being set - a compressor protection will be in progress
	Defrost LED - If the LED is on, defrost is in progress - pre-dripping is in progress If the LED is flashing: - defrost will be requested but a compressor protection will be in progress - dripping will be in progress - defrost will be requested but a compressor minimum switch-on shall be in progress
	Evaporator fan LED If the LED is on the evaporator fan will be on If the LED is flashing evaporator fan standstill will be in progress
AUX	Auxiliary LED If the LED is on: - the room light will be on in manual mode - the demister heating elements will be on - the auxiliary output will have been turned on in manual mode - the alarm output will be active - the door heating elements will be on - the neutral area operation heating elements will be on - the condenser fan will be on - the on/stand-by output shall be active If the LED is flashing: - the room light will be on by door switch input - the auxiliary output will have been turned on from the multifunction input - the condenser fan will be delayed in turning off
	Energy saving LED If the LED is on and the display is switched on, the “energy saving” function is in progress If the LED is on and the display is switched off, the “low consumption” function is in progress; touch a key to restore normal display
	Maintenance LED if it is on, the compressor must be maintained
°C	Celsius degrees LED If the LED is on, the unit of measurement for temperature is Celsius degrees If it is flashing, the “rapid cooling” or “rapid heating” function will be in progress
°F	Fahrenheit degrees LED If the LED is on, the unit of measurement for temperature is Fahrenheit degrees If it is flashing, the “rapid cooling” or “rapid heating” function will be in progress
	LED on/stand-by If the LED is on, the device is switched off (“standby” status)

Signals

CODE	MEANING
Loc	the keyboard is blocked
- - -	the operation requested is not available
dEF	defrost is in progress

Alarms

CODE	MEANING
AL	Minimum temperature alarm Solutions: - check the room temperature or CPT temperature; see A1 parameter Main consequences: - the alarm output will be switched on
AH	Maximum temperature alarm Solutions: - check the room temperature or CPT temperature; see A4 parameter Main consequences: - the alarm output will be switched on

id	Door switch input alarm Solutions: - check the causes of the activation of the input; see i0 and i1 parameters Main consequences: - the effect established with the i0 parameter - the alarm output will be switched on
iA	Multifunction input alarm Solutions: - check the causes of the activation of the input; see i5 and i6 parameters Main consequences: - the effect established with the i5 parameter - the alarm output will be switched on
COH	Condenser overheated alarm Solutions: - check the condenser temperature; see C6 parameter Main consequences: - the alarm output will be switched on - the condenser fan will be switched on
CSd	Compressor shut down alarm Solutions: - check the condenser temperature; see C7 parameter - switch the device off and back on again: if when the device is switched back on, the temperature of the condenser is still higher than that established in C7 parameter, disconnect the power supply and clean the condenser Main consequences: - the compressor will be switched off - the alarm output will be switched on - the condenser fan will be switched on
Cth	Compressor thermal protection alarm Solutions: - check the causes of the activation of the multifunction input; see i5 and i6 parameters Main consequences: - the compressor will be switched off - the alarm output will be switched on
th	Global thermal protection alarm Solutions: - check the causes of the activation of the multifunction input; see i5 and i6 parameters - check that the cause that triggered the alarm has been eliminated and switch the device off and back on again or disconnect the power supply Main consequences: - all utilities will be switched off - the alarm output will be switched on
dFd	Defrost alarm switched off because maximum time has been reached Solutions: - check the integrity of the evaporator probe; see d2, d3 and d11 parameters - touch a key to restore normal display Main consequences: - the device will continue to operate normally

When the cause of the alarm disappears, the device restores normal operation, except for the following alarms:

- the compressor blocked alarm (code "CSd") and the global thermal protection alarm (code "th"), which both need to be reset by turning the device off or switching off the power supply.
- defrost alarm switched off because maximum time has been reached (code "dFd") which requires the touching of a key.

Errors

CODE	MEANING
Pr1	Room temperature probe or inlet air probe error Solutions: - check that the probe is the PTC or NTC type; see P0 parameter - check the device-probe connection - check room temperature/CPT temperature Main consequences: - compressor activity will depend on C4 and C5 parameters - if the P4 parameter is set at 3, the temperature associated with the regulation and the temperature alarms shall be the outgoing air temperature - the defrost will not be activated - the alarm output will be switched on - the door heating elements shall be turned off - the neutral area operation heating elements will be turned off
Pr2	Evaporator probe error Solutions: - the same as in the previous example, but with regard to the evaporator probe Main consequences: - if P3 parameter is set at 1, the defrost interval will last for the amount of time set with d3 parameter - if P3 parameter is set at 1 and d8 parameter is set at 2 or to 3, the device will operate as if d8 parameter were set at 0

	- if P3 parameter is set at 1 or 2 and F0 parameter is set at 3 to 4, the device will operate as if parameter were set at 2 - the alarm output will be switched on
Pr3	Condenser probe error, critical temperature probe or outflowing air probe Solutions: - the same as in the previous example, but with regard to the condenser probe, the critical temperature probe or the outflowing air probe Main consequences: - if P4 parameter is set at 1, the condenser overheated alarm (code "COH") will never be activated - if P4 parameter is set at 1, the compressor shut down alarm (code "CSd") will never be activated - if P4 parameter is set at 1, the condenser fan shall work in parallel with the compressor - if the P4 parameter is set at 3, the temperature associated with the temperature alarms shall be the inflowing air temperature - the alarm output will be switched on

When the cause of the error disappears, the device restores normal operation.

WORKING IRREGULARITIES

In case of working irregularities, before to call the technical service in zone verify that:

- the main switch 1 is lighting and the current is present;
- the regulated temperature is the wished one;
- the doors are perfectly closed;
- the machine is not near heat sources;
- the condenser is clean and the fan works regularly;
- an excess of hoarfrost does not cover the evaporating panel.

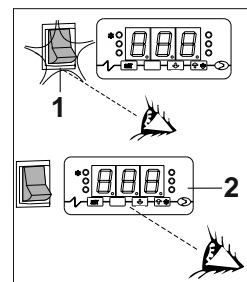

In case of negative result, contact the nearest service centre indicating the model (1) and the serial number (5) shown on the rating placed on the appliance instrument panel.

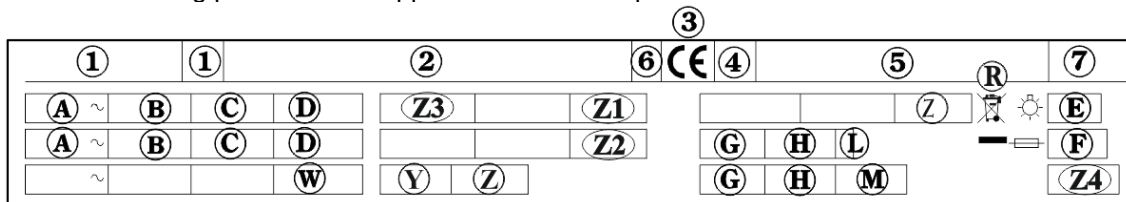

GENERAL CLEANING AND MAINTENANCE

For a constant efficiency of the refrigerator it is recommended to perform the cleaning and maintenance operations.

Before to begin with the operations proceed as following:

- set the general cut-out in OFF position
- remove the plug from the socket and wait till the complete entfrosting of the refrigerator.

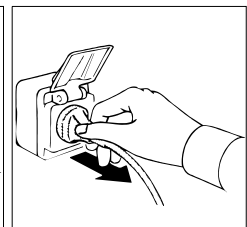
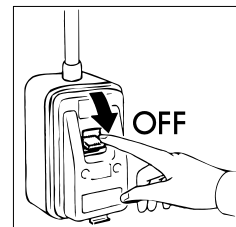

Accurately clean the condenser in the refrigerating unit and the inner evaporator with either a vacuum cleaner, a bristle brush or a non-wire brush after removing the protections.

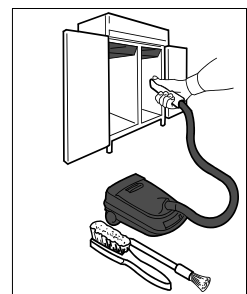

WARNING: The cleaning and maintenance of the refrigerating engine and the compressor area needs the intervention of a skilled technician, therefore it cannot be

done by other persons.

Clean the external and internal surfaces with water and neutral soap or detergent; a little vinegar in the water will remove eventual bad smells. Rinse abundantly with pure water and dry up accurately.

The cleaning and maintenance operations have now come to end.

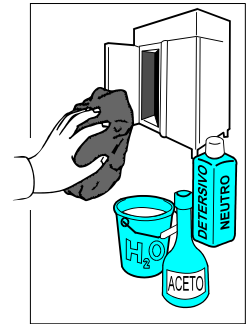

MAINTENANCE CABINETS STAINLESS STEEL

DAILY CLEANING

To guarantee a perfect hygiene and conservation of the refrigerated cabinet it is recommended to carry out often and/or daily the cleaning operations as indicated hereunder:

1. Clean carefully the cabinet surfaces, only in the direction of the etching, with a soft wrung out sponge drenched with water and neutral detergent.
2. The detergents must not contain chlorine and must not be abrasive.
2.a The kind of detergents recommended are the ones indicated hereunder:
 - Composite action disinfecting detergent; (containing non-ionic surfactants, benzalkonium chloride, chelating agents and pH buffer)
 - Laboratory, neutral detergent for hand washing; (containing anionic and non-ionic surfactants)
 - Food environments degreasant; (containing anionic surfactants and EDTA)
3. Before using the detergents, dilute them, if needed, following the instructions on the label.
4. Leave the detergents act for at least 5 minutes.
5. Rinse carefully the fridge walls with a sponge drenched in running water.
6. Dry carefully using a clean sponge.

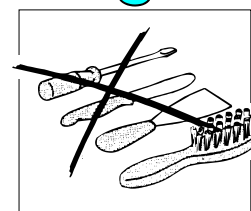
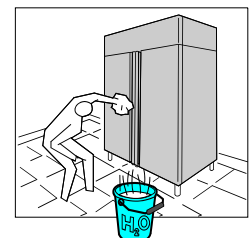
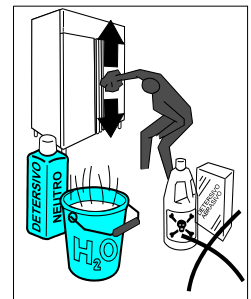

WARNING: absolutely do not use utensils or materials which could cause cuts and consequently rust formations.

FOOD STAINS AND HARDENED RESIDUES

In case there are food or waste stains in the fridge, wash the surfaces with water and clean them off before they might harden.

If the wastes have already hardened, please follow the instructions hereunder:

1. Use a soft sponge drenched with lukewarm water and neutral detergent (you can use the detergents for the daily cleaning operations, at the highest concentration estimated by the label).
2. Dampen the hardened waste so as to maintain it damp for at least 30 minutes passing on it every five minutes the sponge drenched with water and detergents on the hardened dirty area.



3. At the end of this soaking operation remove the waste with the sponge drenched with water and neutral detergents.
4. If needed, use a wooden spatula or a fine stainless-steel sponge, taking care of not damaging the fridge surface.
5. At the end of this process it is recommended a daily cleaning operation cycle of all the internal surfaces of the fridge.
6. When the cleaning operations are over, rinse carefully with a sponge drenched with running water.
7. Dry carefully using a clean sponge.

The space around and under the refrigerator must also be cleaned and held in perfect hygiene.

Clean using water and neutral soap or detergent.

Protect the sheet metal parts with silicon wax.

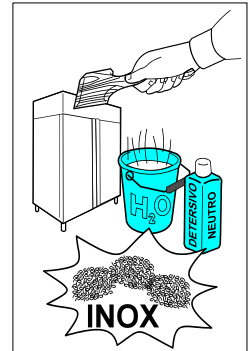

USEFULL ADVICES FOR THE CARE OF THE STAINLESS STEEL

For the cleaning and maintenance of the parts of stainless steel follow the advices written below, bearing in mind that the first and fundamental rule is to guarantee the non toxicity and best hygiene of the dealed products.

The stainless steel has a thin oxide coat that prevents rust formation.

But there are substances or detergents that can destroy this coat and give origin to corrosions.

Before using any detergent product ask always your dealer about which neutral detergent is the most qualified and does not cause corrosions on the steel.

In case of scratches on the surfaces it is necessary to smooth them using thin STAINLESS STEEL wool or an abrasive sponge in synthetic fibrous material, wiping in the direction of the satin.

WARNING: for the cleaning of the STAINLESS STEEL never use iron wool and never let them rest on the surfaces because little iron deposits could remain on the surfaces and cause rust formations by contamination and endanger the hygiene.

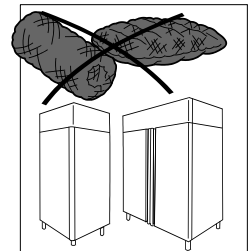
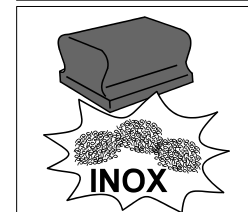
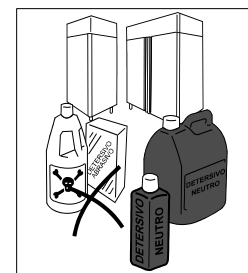

MAINTENANCE CABINETS VX-PET

To guarantee a perfect hygiene and conservation of the refrigerated cabinet (66) it is recommended to carry out often and/or daily the cleaning operations.

Any food stains or residue on the outside surface should be removed with water before they harden.

Remove any hardened food residue with a soft sponge dipped in oil of turpentine or denatured alcohol.



Any food stains or residue on the inside surface should be removed with a soft cloth and hot white vinegar or denatured alcohol. Clean respecting the satinizing direction.

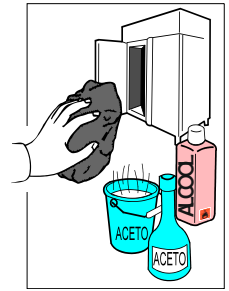

Daily cleaning of all inside surfaces of the appliance is recommended.

Do not use any abrasive paste or steel wool, acetone, trichloroethylene or ammonia.

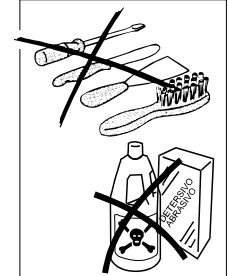

When the cleaning operations are over, rinse carefully with a sponge drenched with running water.

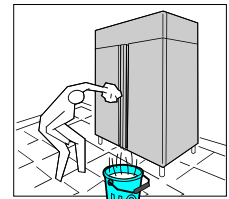

Dry carefully using a clean sponge.

The space around and under the refrigerator must also be cleaned and held in perfect hygiene. Clean using water and neutral soap or detergent.



USAGE INTERRUPTIONS

In case of longer inactivity of the refrigerator and for maintaining it in the best state act as following:

- set the general cut-out in OFF position.
- remove the plug from the socket.

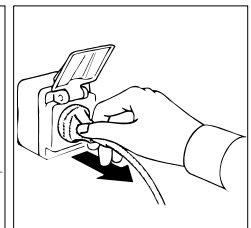
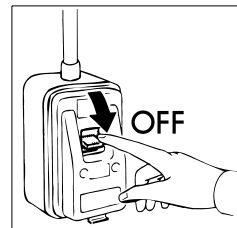

- empty the refrigerator and clean it as described in the chapter "CLEANING".

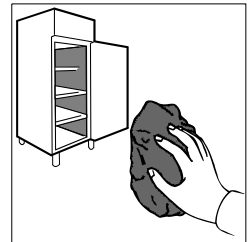

- let the doors open to avoid the forming of bad smell.
- cover compressor set with a nylon sheet to protect it from dust.

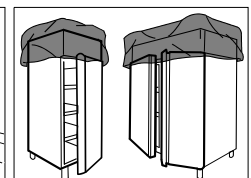
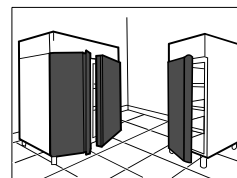

MALFUNCTIONING

Malfunctioning during operation is often due to banal causes, which may nearly all be resolved without the help of a specialised technician. Consequently, before getting in touch with a service centre, check the following:

PROBLEM	POSSIBLE CAUSES
The appliance does not start	Check that the plug is properly inserted into the socket.
	Check that there is voltage at the socket
The internal temperature is too high	Check the thermostat setting
	Check for a heat source in the vicinity
	Check that the door closes properly
The appliance is excessively noisy	Check that the appliance is standing level. A lopsided appliance could set off vibrations
	Check that the appliance is not touching other appliances or parts which could resonate
There are unpleasant smells inside the refrigerator	There are foodstuffs with a particularly strong smell (for example cheese and melon), placed in non-sealed containers
	Internal surfaces must be cleaned
Some condensation is produced on the appliance	Room humidity is very high
	Doors are not well-closed

Upon completion of the above checks, if the fault persists, contact an authorised service centre. Always indicate:

- the nature of the fault
- the model and the serial number that can be found on the technical feature plate, placed under the appliance instrument panel.

WASTE DISPOSAL AND DEMOLITION

WASTE STORAGE

At the end of the product life, avoid release to the environment. The doors should be removed before disposal.

Temporary storage of special waste is permitted while waiting for disposal by treatment and/or final collection. Dispose of special waste in accordance with the laws in force with regard to protection of the environment in the country of the user.

PROCEDURE FOR ROUGH DISMANTLING THE APPLIANCE

All countries have different legislation; provision laid down by the laws and the authorised bodies of the countries where the demolition takes place are therefore to be observed.

A general rule is to deliver the appliance to specialised collection and demolition centres. Dismantle the refrigerator grouping together the components according to their chemical nature. The compressor contains lubricating oil and refrigerant, which may be recycled. The refrigerator components are considered special waste, which can be assimilated with domestic waste.

Make the appliance totally unusable by removing the power cable and any door locking mechanisms in order to avoid the risk of anyone being trapped inside.

DISMANTLING OPERATIONS SHOULD BE CARRIED OUT BY QUALIFIED PERSONNEL.

THE SAFE DISPOSAL OF WASTE FROM ELECTRICAL AND ELECTRONIC EQUIPMENT (WEEE DIRECTIVE 2002/96/EC)

Do not dump pollutant material in the environment. Dispose of it in compliance with the relevant laws.

Under the WEEE (Waste Electrical and Electronic Equipment) Directive 2002/96/EC, when scrapping equipment the user must dispose of it at the specific authorised disposal centres, or reassign it, still installed, to the original seller on purchase of new equipment.

All equipment which must be disposed of in accordance with the WEEE Directive 2002/96/EC is marked with

a special symbol .

The improper disposal of Waste Electrical and Electronic Equipment is liable to punishment under the relevant laws in the countries where the offence is committed.

Waste electrical and Electronic Equipment may contain hazardous substances with potential harmful effects on the environment and human health. You are urged to dispose of them properly.

INVERTING THE DOOR (exception made for glass door versions)

Refrigerator cabinets are normally supplied with opening to the right.

To invert the door (hinge on the left side) follow this procedure:

- Rotate the instrument panel on the side heads by removing the "F" screw.
Warning: in models "...T" and "Ice cream" also remove the panel by unscrewing the screws "X" found on the side heads over to the vine "stops" dashboard "F".
- Remove the two fixing screws of the bracket "A" and the holding screw of the hinge "B".
- Extract the door, remove the hinge "B" and the component "E" and invert their position.
- Remove the component "C" and install it on the opposite side of the door.
- Remove the lower bracket "d" and install it in its housing on the opposite side.
- Place the door by introducing the hole of the lower component "E" into the pin of the bracket "D".
- Fix the bracket "A" to the structure on the opposite side by tightening the fixing screws.
- Before tightening the bracket screws, check the hinge height (12 mm approx.) and the door perpendicular position with respect to the structure.
- Replace the panel board

NOTE: Keep the door closed when removing and installing the brackets.

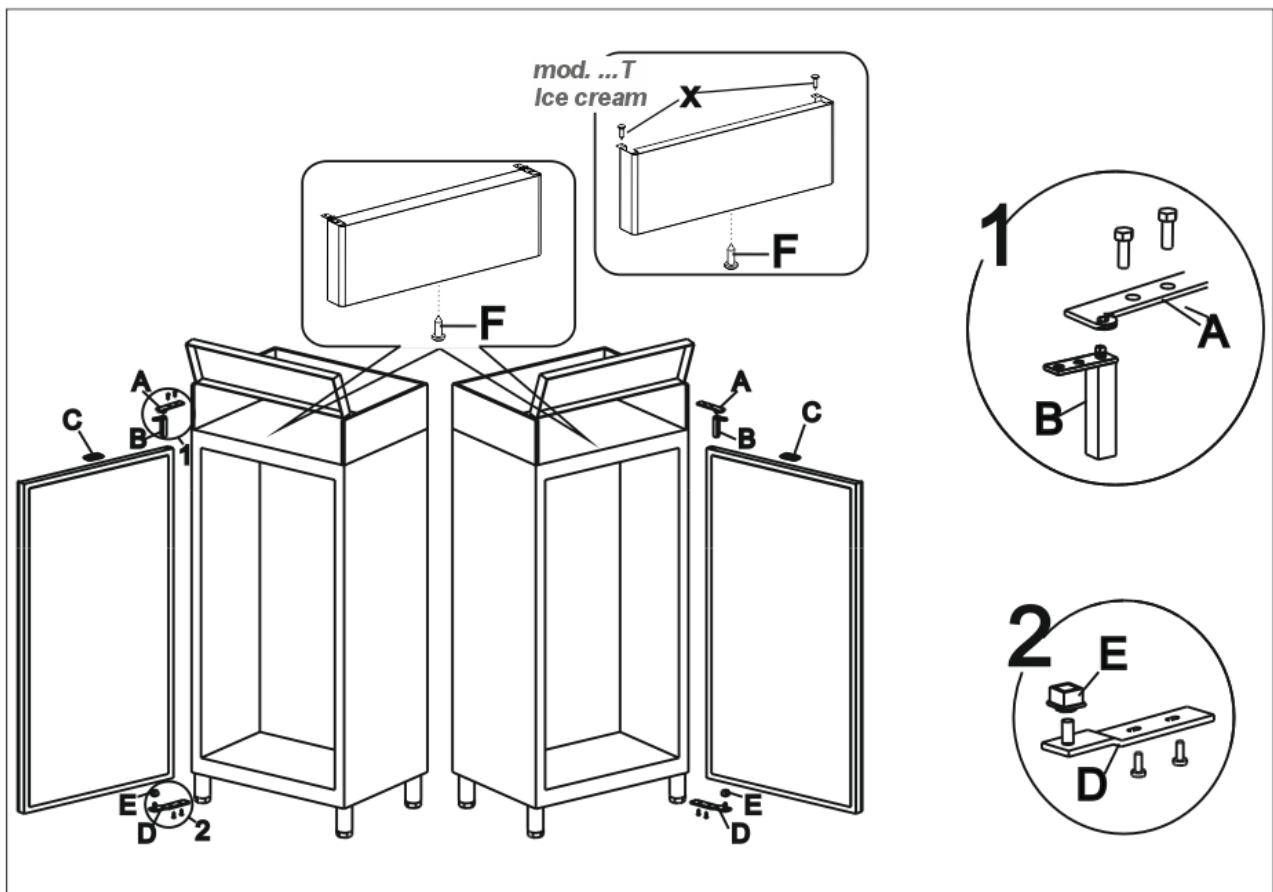

INVERTING THE 1/2 DOOR

Cold stores are equipped with door opening to the right.

When inverting door opening, proceed as follows:

- Rotate the instrument panel on the side heads by removing the "F" screw.
- Remove the two fixing screws of the bracket "A" and the holding screw of the hinge "B".
- Remove the upper door ; disassemble the hinge "B" and the component "E", then reverse their assembly.
- Remove the component "C" and install it on the opposite side of the door.
- Remove the middle bracket "G" and re-install it in its specific seat on the opposite side.
- Remove the lower door ; disassemble the hinge "B" and the component "E", then reverse their assembly.
- Move the lower door micro to the opposite side using the specific hole.
- Remove the lower bracket "D" and re-install it onto the component "B" located on the lower door.
- Set the lower door introducing the component "E" in the pin of the bracket "G".
- Fix the bracket "D" tightening the fixing screws thoroughly.
- Place the bracket "A" on the component "B" located on the upper door.
- Set the upper door introducing the component "E" in the pin of the bracket "G".
- Fix the bracket "A" tightening the fixing screws thoroughly.
- Before tightening the bracket screws, check the hinge height (12 mm approx.) and the door perpendicular position with respect to the structure.
- Replace the instrument panel.

NOTE: Keep the door closed when removing and installing the brackets.

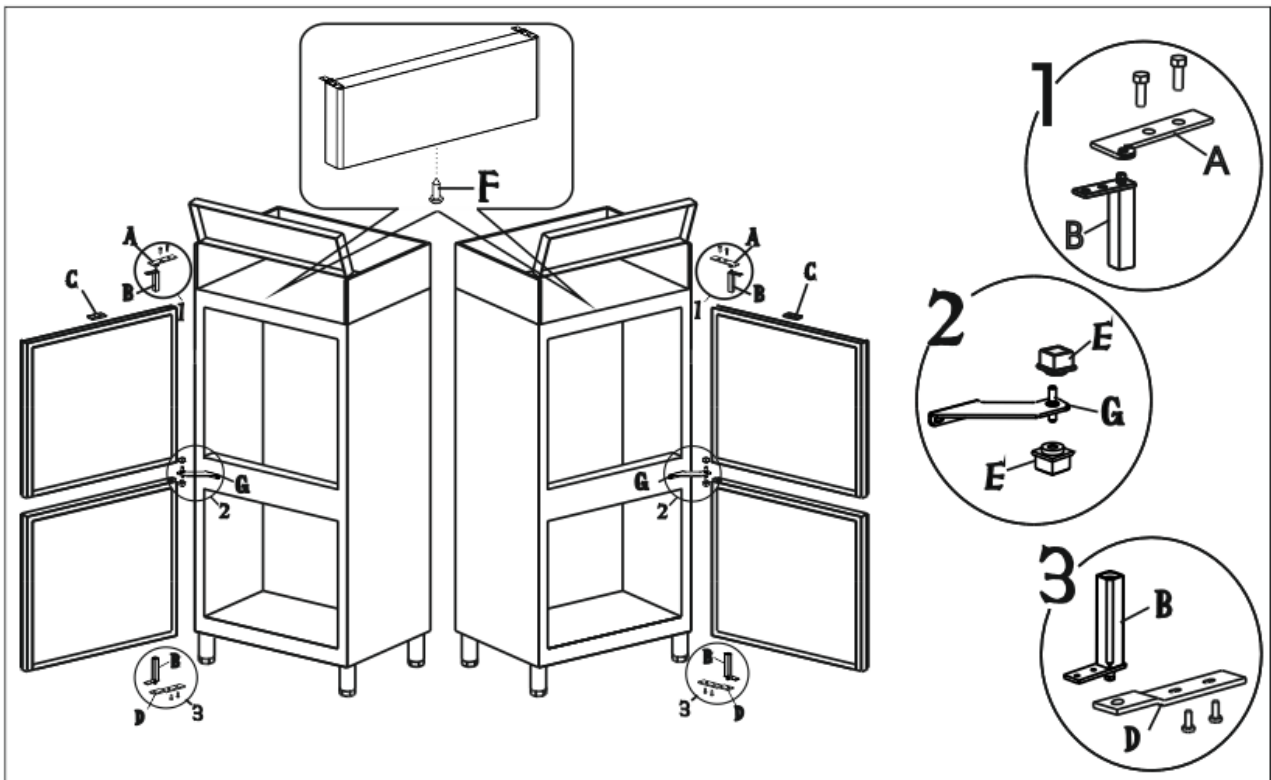

REFRIGERANT MATERIAL SAFETY DATA SHEET

1) R134a

GWP = 1300

ODP = 0

2) R404A : fluid components

• trifluoroethane (HFC 143a) 52%

• pentafluoroethane (HFC 125) 44%

• tetrafluoroethane (HFC 134a) 4%

GWP = 3922

ODP = 0

❖ Hazard identification

Overexposure through inhalation may cause anaesthetic effects. Acute overexposure may cause cardiac rhythm disorders and sudden death. Product mists or sprays may cause ice burns of eyes and skin.

❖ First aid procedures

• *Inhalation:*

keep injured person away from exposure, warm and relaxed. Use oxygen, if necessary. Give artificial respiration if respiration has stopped or is about to stop. In case of cardiac arrest give external cardiac massage. Seek immediate medical attention.

• *Skin:*

use water to remove ice from affected areas. Remove contaminated clothes.

CAUTION: clothes may adhere to skin in case of ice burns.

In case of contact with skin, wash with copious quantities of lukewarm water. In case of symptoms (irritation or blisters) seek medical attention.

• *Eyes:*

immediately wash with ocular solution or fresh water, keeping eyelids open for at least 10 minutes. Seek medical attention.

• *Ingestion:*

it can cause vomit.. If conscious, rinse mouth with water and drink 200-300 ml of water. Seek medical attention.

• *Other medical treatment:*

symptomatic treatment and support therapy when indicated. Do not administer adrenaline or sympathicomimetic drugs after exposure, due to the risk of arrhythmia and possible cardiac arrest.

❖ Environmental data

Persistence and degradation

• *HFC 143a:*

slow decomposition in lower atmosphere (troposphere). Duration in atmosphere is 55 years.

• *HFC 125:*

slow decomposition in lower atmosphere (troposphere). Duration in atmosphere is 40 years.

• *HFC 134a:*

si decompone con relativa rapidità nell'atmosfera inferiore (troposfera). La durata nell'atmosfera è 15,6 anni.

• *HFCs 143a, 125, 134a:*

does not affect photochemical smog (not included in volatile organic components – VOC – as established in the UNECE agreement). Does not cause ozone rarefaction.

Product exhausts released in the atmosphere do not cause long-term water contamination.

3) R600a o R290

GWP = 3

ODP = 0

❖ Hazards identification

Liquefied gas - Extremely flammable

❖ First aid measures

• *Inhalation:*

In high concentrations may cause asphyxiation. Symptoms may include loss of mobility and/or consciousness. Victims may not be aware of asphyxiation. In low concentrations, may cause narcotic effects. Symptoms may include dizziness, headache, nausea and loss of coordination. Remove victim to an uncontaminated area wearing self contained breathing apparatus. Keep the patient relaxed and warm. Call a physician. Apply artificial respiration if breathing stops..

• *Contact with skin and eyes:*

In case of spillage, rinse thoroughly with water for at least 15 minutes

• *Ingestion:*

Route of exposure unlikely

❖ Informazioni ecologiche

Ecological information No known ecological damage caused by this product

WIRING DIAGRAM PLATE

The electrical diagram is shown on the last page of the booklet.

Pos	DESCRIPTION	Pos	DESCRIPTION
1	COMPRESSOR UNIT	29	TL LAMPS BALLAST
2	COMPRESSOR FAN	30	STARTER
3	GENERAL TERMINAL BOARD	31	TL LAMP
6	MAIN SWITCH WITH PILOT	44	RELAY COMPRESSOR
8	PLUG	44A	RELAY PTC
9	EVAPORATOR FUN	44B	RELAY MAGNETIC MICRO-SVWITCH
9A	EVAPORATOR FUN	56	FILTER
9B	EVAPORATOR FUN	69	GROUNDING TERMINAL
10	INTERNAL LIGHTING LAMP	75	SOLENOID VALVE
10A	INTERNAL LIGHTING LAMP	76	MAGNETIC MICRO-SVWITCH
12	SOLENOID VALVE DEFROSTING	85	CONNECTION BOX
19	THERMOSTAT PILOT	90	DIGITAL THERMOREGULATOR
20	DOOR ANTICONDENSING RESISTOR	91	PTC RESISTOR
20A	DOOR ANTICONDENSING RESISTOR	96	ELECTRONIC CARD
21	TRY BOTTOM RESISTOR	101	BUFFER RESISTANCE
22	RESISTANCE FOUND BASIN	102	BIMETALLIC SAFETY THERMOSTAT
25	TRANSFORMER	113	MICROSWITCH 4 CONTACTS
28	INTERNAL LIGHTING SWITCH	113A	MICROSWITCH 4 CONTACTS

