

50Hz

iT0420 Ice Cube Machine

iT0420 Ice Cube Machine

Models

- IDT0420A IYT0420A



Indigo NXT Series iT0420 Ice Machine on D320 Bin

Designed for operators who know that ice is critical to their business, the Indigo NXT Series ice machine's preventative diagnostics continually monitor itself for reliable ice production. Improvements in cleanability and programmability make your ice machine easy to own and less expensive to operate.

- **New levels of Performance** – Showcasing an average increase of 65% in ice production, 26% reduction in energy usage and 21% reduction in potable water usage. This translates into lower cost of ownership over the life of your machine.
- **easyTouch® Display** - New icon based touch screen takes the guess work out of owning and operating an ice machine.
- **Multiple Language Capability** - The easyTouch display is available in multiple languages selected in the initial start-up installation Wizard.
- **Programmable Ice Production** – Now its super easy to program your ice machine to be off at certain times of the day to save money with fluctuating electrical rates. Also programmable by daily ice production volume.
- **Easy to Clean Foodzone** – Hinge front door swing out for easy access. Removable water-trough, distribution tube, curtain, water probe and water pump for fast and efficient cleaning. Selected components are made with AlphaSan® antimicrobial.
- **Intelligent Diagnostics** – Provides 24 hour preventative maintenance and diagnostic feedback for trouble free operation.
- **Acoustical Ice Sensing Probe** – Unique patented technology allows for reliable operation in challenging water conditions and environments
- **DuraTech® Exterior** – Provides superior corrosion resistant above stainless steel. Innovative clear-coat resists fingerprints and dirt making it easier to keep clean.
- **Available Luminice II Virus and Bacteria Inhibitor**- Controls viruses, bacteria, mold and yeast within the foodzone to keep the machine clean longer. A new sanitation icon lets you know the operational status.
- **Active Sense** – insures consistent ice harvest in all environmental conditions. This software solution works in conjunction with the acoustical ice sensing probe improving reliability and performance.



Ice Machine Electric

230/50 /1

Minimum circuit ampacity:

Air-cooled: 5.7

Maximum fuse size:

Air-cooled: 15 1ph

Power Consumption: 849 W

Specification

BTU Per Hour:
3,800 (average),
and 6,000 (peak)

Refrigerant:

R410A - CFC Free
Lowers global warming
by 48%

Operating Limits:

- Ambient Temperature Range:
40° to 110° F (4.4° to 43.3° C)
Water Temperature Range:
40° to 90° F (4.4° to 32.2° C)
- Water Pressure Ice Maker
Water In:
Min. 20 psi (137.9 kPa)
Max. 80 psi (551.1 kPa)

Ice Shape



Half Dice
3/8" x 1 1/8" x 7/8"
(.95 x 2.86 x 2.22 cm)
Cube weight 5.7 g



Dice
7/8" x 7/8" x 7/8"
(2.22 x 2.22 x 2.22 cm)
Cube weight 8.5 g



COMPANY WITH
QUALITY SYSTEM



50Hz

Indigo® NXT™ iT0420 Ice Cube Machine

iT0420 on D320 Storage Bin

- Ⓐ Electrical Entrance (2) Options
- Ⓑ 3/8" (0.95 cm) F.P.T. Water Condenser Inlet (water-cooled units)
- Ⓒ 1/2" (1.27 cm) F.P.T. Water Condenser Outlet (water-cooled units)
- Ⓓ 1/2" (1.27 cm) Auxiliary Base Drain Socket
- Ⓔ 3/8" (0.95 cm) F.P.T. Ice Making Water Inlet
- Ⓕ 1/2" (1.27 cm) F.P.T. Ice Making Water Drain
- Ⓖ 3/4" (1.91 cm) Bin Drain

Installation Note
Minimum installation clearance:
Top/side: 12" (30.50 cm)
Back is 5" (12.7 cm)

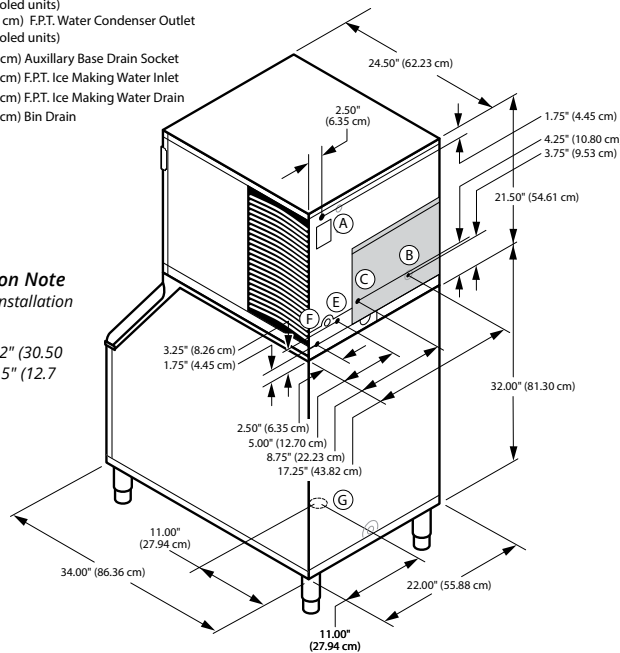

Space-Saving Design



	iT0420 D320	iT0420 D420
Height	59.50" 151.13 cm	71.50" 181.61 cm
Width	22.00" 55.88 cm	22.00" 55.88 cm
Depth	34.00" 86.30 cm	34.00" 86.30 cm
Bin	264 lbs.	383 lbs.
Storage	118 kgs.	174 kgs.

Height includes adjustable bin legs 6.00" to 8.00", (15.24 to 20.32 cm) set at 6.00" (15.24 cm).
Bin capacity is based on 90% of the volume x 33 lbs/ft³ average density of ice.

Specification

AIR COOLED	Model	Ice Shape	Ice Production 24 Hours		Power Usage kWh 45.4 kg / 100 lbs @ 32°Air / 21°C Water 90°Air / 70°F Water	Potable Water Usage/100 lbs. 45.4 kgs. of Ice
			21°Air / 10°C Water 70°Air / 50°F Water	32°Air / 21°C Water 90°Air / 70°F Water		
			1 Ph			
IDT0420A	dice		450 lbs.	360 lbs.	5.6	19 Gal.
			204 kgs	163 kgs		72 L
IYT0420A	half-dice		450 lbs.	360 lbs.	5.4	19 Gal.
			204 kgs	163 kgs		72 L

Order separately: Ice storage bin for all units
This product is hermetically sealed and contains fluorinated greenhouse gas R410A

Accessories

LuminIce® II Virus and Bacteria Inhibitor
controls viruses and bacteria inside the ice machine.



External Scoop holder
Protect the ice scoop with the NSF approved versatile scoop holder.

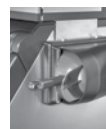

Arctic Pure® Water Filters
Reduces sediment and chlorine odors for better tasting ice.



Manitowoc reserves the right to make changes to the design or specifications without prior notice